



FIRE ALARM ASPIRATION SENSING TECHNOLOGY™

**Reverse Flush Cleaning System for the
FAAST Range of Aspirating Detectors
F-BO-AFE70-2**

Description

Installation - Connection - Commissioning - Maintenance

SYSTEM SENSOR EUROPE

Pittway Tecnologica S.r.l.

Via Caboto 19/3

34147 TRIESTE

Italy

www.systemsensoreurope.com

Important information for the installer for the use of a Purging unit in a fire detection system

Fire detection systems are designed to protect people and property from the dangers of a fire. These devices are used to detect fires and to raise alarms as early as possible. Therefore, these systems have to be planned, installed and put into operation very carefully by trained personnel.

For the handling of compressed air or for the installation of a compressed-air system, country-specific qualifying examinations or approvals may be required. In addition, for the installation, commissioning and maintenance of the Automatic Purging Units Series F-BO-AFE70-2, you must follow the special precautions listed below.



Before starting any work on the Purging unit, the supply voltage of the Purging unit as well as the compressed-air supply must be reliably interrupted, and measures must be taken to ensure that they are not switched back on unintentionally!



Only turn on the compressed-air supply after finishing all mounting, installation, connection and parameterisation work in the course of commissioning, as described starting on page 38 in Chapter 9: „Commissioning and function test“. Turning on the compressed-air supply at an earlier time can result in serious personal injuries or damage to property, depending on the condition of the system and the environment.



When carrying out any work, do wear sufficient personal protective gear, for example, wear eye protection and hearing protection when working with compressed air.



Take care that fingers, other parts of the body, and objects never get into the pipe connection openings. During the Purging process, the valve that is integrated into the Automatic Purging Unit Series F-BO-AFE70-2 is closed with high velocity and great force. As a result, parts of the body or objects, which are in the valve body, can be seriously injured or even severed or destroyed respectively! In addition, the Purging unit can be severely damaged or destroyed as a result.



Only service specialists whose employees can provide proof that they have been trained for these tasks are allowed to plan, install, modify, maintain and service a fire detection system.

Fire detection and/or extinguishing systems must be checked and maintained regularly (at least once a year, local regulations may also stipulate shorter intervals) by trained personnel in order to maintain their functionality, on the one hand, and to avoid false alarms to the greatest extent possible on the other.



Parts of a fire detection or extinguishing system that are experiencing a fault, are not able to perform their functions efficiently or can not do so at all. Therefore, faults must be repaired immediately by a trained and authorized specialised company.

In addition to the careful and expert manipulation, the safe operation of smoke aspiration systems requires, above all, the proper transport, storage, installation and commissioning.

The special requirements for the installation of a fire detection system are not described in this User Manual.

Safety instructions

Before installing, commissioning, servicing or using the product described in this User Manual, you have to read the User Manual carefully and, in particular, you have to note and subsequently follow the safety instructions given on pages 3 and 4 as well as in Chapter 1.5: „Important tips“ from page 8 onwards.

Furthermore, the pictographs that are described in Chapter 1.3: „Types of symbols“ from page 8 onwards are very important for you – these pictographs are used frequently throughout this User Manual to remind you of dangers that may arise in case of improper use of the product, as well as to point to valuable tips.

Pressure Equipment / CE-labelling / Construction Products Regulation

Within the EU, pressure equipment is subject to the Directive 2014/68/EU of the European Parliament and of the Council of 15 May 2014 on the harmonisation of the laws of the member states regarding making pressure equipment available on the market. In Austria the guideline has been implemented with the „Druckgeräteverordnung“ (DGVO), in Germany it has been implemented with the „Vierzehnte Verordnung zum Produktsicherheitsgesetz (Druckgeräteverordnung – 14. ProdSV)“.

According to §8 of the DGVO, the Automatic Purging Units Series F-BO-AFE70-2 are pressure equipment with low risk potential, and according to article 4, paragraph 3 of the Directive 2014/68/EU they are „Pressure equipment and assemblies below or equal to the limits set out in points (a), (b) and (c) of paragraph 1 and in paragraph 2 respectively (...)“ and are designed and manufactured in accordance with the sound engineering practice of a Member State. Therefore they must not bear the CE-labelling according to §23 DGVO and article 18 of the guideline 2014/68/EU, but they may be placed on the market within the European Economic Area and may be used there.

The CE-labelling results from a guideline from the board of the European Community for the equivalency of the laws of its member states, including the mutual approval of laws. By means of the CE-label that is affixed to the device, the manufacturer confirms the conformity of the product with the following standards and guidelines:

- ◆ Electromagnetic Compatibility Directive: 2014/30/EU, EN 55022:2010, EN 50130-4:2011 + A1:2014.

The CE-labelling of the device expressly does not result from the guideline 2014/68/EU.

Smoke aspiration systems for use in fire detection and fire alarm systems installed in buildings must bear a CE-label for use within the EU. By means of the CE-label, the manufacturer confirms the compliance with the respective EC Directives as condition for placing products on the market within the European Economic Area, particularly that the product is in conformity with the general low voltage directives, electromagnetic compatibility directives and standards, as well as in the case of smoke aspiration systems, the compliance with the European Standard EN 54-20 (Aspirating smoke detectors).

In addition, within the EU the compliance with the standard EN 54-20 is regulated by the Construction Products Regulation EU 305/2011 (formerly Construction Products Directive 89/106/EEC).



You must not exceed the values specified in the project planning guidelines of the smoke aspiration system. In particular, make sure that the project planning is carried out in accordance with the current version of EN 54-20.

However, the Automatic Purging Units Series F-BO-AFE70-2 do not represent an additional air resistance in the sensor piping, and therefore they do not have to be additionally included in the calculation of the sensor pipe.

Contents

1	Introduction.....	7
1.1	General.....	7
1.2	Intended use.....	8
1.3	Types of symbols.....	8
1.4	Abbreviations, special terms.....	8
1.5	Important tips.....	8
1.6	Scope of delivery.....	9
2	Manner of operation of a Purging unit.....	10
2.1	General.....	10
2.2	Characteristic features of the Automatic Purging Units Series F-BO-AFE70-2.....	11
2.3	Usual manner of operation of the Automatic Purging Units Series F-BO-AFE70-2.....	11
3	Displaying of the operating conditions and operation.....	13
3.1	Operating conditions indicated by the status LED.....	13
3.2	Operation by the user.....	14
3.3	Operation by the installer.....	14
4	Pneumatic components – dimensioning.....	15
4.1	Purging unit.....	15
4.2	Compressed-air supply.....	16
5	Final assembly, mechanical structure and dimensions.....	19
5.1	Final assembly.....	19
5.2	Mechanical structure.....	20
5.3	Dimensions.....	21
6	Safety devices.....	22
7	Mounting and connection of pneumatic components.....	23
7.1	Location of installation.....	23
7.1.1	Permissible mounting positions.....	23
7.1.2	Installation of the Automatic Purging Units Series F-BO-AFE70-2.....	23
7.2	Connection to the sensor pipe and to the evaluation unit of the smoke aspiration system.....	24
7.2.1	Loosening the pipe connection.....	25
7.2.2	Use of filters.....	25
7.2.3	Use of check valves.....	26
7.2.4	Connection diagram for a double pipe system.....	26
7.2.5	Connection diagram for far-flung sensor pipe networks with master-slave mode of the Purging units.....	27
7.3	Connection of the compressed air.....	28
8	Connection and parameterisation.....	29
8.1	General instructions.....	29
8.2	Power supply.....	30
8.3	Location of the display and operating elements and terminals on the control board of the Automatic Purging Units Series F-BO-AFE70-2.....	30
8.4	Connection of and interaction between Purging unit, smoke aspiration system and fire detection control panel.....	30
8.4.1	Standard connection.....	31
8.4.1.1	Push-button „Manual activation“	31
8.4.1.2	Output „Slave activation“	32
8.4.1.3	Synchronisation of the internal clock of the F-BO-AFE70-2	32
8.4.2	Connection of Purging units in the master-slave mode.....	32
8.5	Parameterisation of the Purging unit.....	34
8.5.1	Setting the Purging program.....	34
8.5.2	Internal clock.....	35
8.5.2.1	Displaying and manually setting the time	35

8.5.2.2	Automatically synchronising the time	36
8.5.3	Setting and displaying the device number.....	36
8.6	Label showing the parameterisation options and connection possibilities.....	37
9	Commissioning and function test.....	38
10	Inspection.....	40
11	Specifications.....	41
12	Set parameters.....	43

1 Introduction

1.1 General

This User Manual of the Automatic Purging Unit Series F-BO-AFE70-2 provides the authorized installer with the information necessary for planning, configuration, installation, connection, parameterisation, commissioning and maintenance of the Automatic Purging Units Series F-BO-AFE70-2.



The manner of operation of Purging units in general and of the Automatic Purging Units Series F-BO-AFE70-2 in particular are described from page 10 onwards in Chapter 2: „Manner of operation of a Purging unit“.



Fig. 1: *View of the Automatic Purging Units Series F-BO-AFE70-2*
 Left picture: Automatic Purging Unit F-BO-AFE70-1 without cover, Automatic Purging Unit F-BO-AFE70-2 with cover
 Right picture: View of the solenoid valve on the Automatic Purging Unit F-BO-AFE70-2

The following types of the Automatic Purging Unit Series F-BO-AFE70 are available:

Type	Name	Art. No.
F-BO-AFE70-1	Automatic Purging Unit/1000L	Not Available
F-BO-AFE70-2	Automatic Purging Unit/3500L	F-BO-AFE70-2

Table 1: *Type code of the Automatic Purging Units Series F-BO-AFE70-2*

The Automatic Purging Units F-BO-AFE70-1 and F-BO-AFE70-2 have outer dimensions and functionality in common, they essentially differ in the built-in solenoid valves which allow different air flow rates. The Automatic Purging Unit F-BO-AFE70-1 with a typical air flow rate of the solenoid valve of approx. 1,000 l/min (ANR) at 0.7MPa (7bar) is designed for smaller pipe networks with few aspiration holes, the Automatic Purging Unit F-BO-AFE70-2 with a typical air flow rate of the solenoid valve of approx. 3,500 l/min (ANR) at 0.7MPa (7bar) is designed for larger pipe networks with a large number of aspiration holes. Notes with regard to dimensioning can be found from page 15 onwards in Chapter 4: „Pneumatic components – dimensioning“. The functions of the Purging units are described starting on page 10 in Chapter 2: „Manner of operation of a Purging unit“.

In the following chapters, differences between the types will only be pointed out specially if they are relevant for the respective topic discussed. In all other cases in this User Manual, the terms „F-BO-AFE70-2“ and „Purging unit“ will generally be understood to mean all design versions mentioned above.

The information in this User Manual relates to the firmware release number PL0200_V_1.00 of the control board. In Fig. 12 the position of the label is indicated where the version of the firmware used can be read. Devices using firmware with another release number can differ in their function from the range of functions described in this document.

1.2 Intended use

The Automatic Purging Units Series AF-BO-FE70 are designed and intended exclusively for purging pipes of smoke aspiration systems for fire detection systems in buildings, within the limits described in this User Manual. Any other use of the devices is expressly not intended and forbidden.



The improper use of the Automatic Purging Units Series AFE70 can endanger life and health or lead to damage to property. The manufacturer does not accept any responsibility for improper use.

1.3 Types of symbols

Especially important sections of text in this User Manual are indicated with symbols. The following symbols are used:



Means **DANGER!** Ignoring these directions can result in danger to life and health.



Means **ATTENTION!** Ignoring these tips can result in system malfunctions or damage to property.



Means **TIP!** Here the text contains tips for easier operation.



Means that the country-specific and/or the site-specific requirements of the **DEVICE** and/or **SYSTEM APPROVALS** of the fire detection system must be observed.

1.4 Abbreviations, special terms

In order to improve the readability of this User Manual, the generic terms „Purging unit“ and „F-BO-AFE70-2“ are used whenever the information in question applies to all versions of the Automatic Purging Unit Series F-BO-AFE70-2.

The terms „control board“ and AFS70-1 refer to the built-in electronic control of the Purging unit.

The term „overpressure“ refers to the difference between the static absolute pressure of the compressed air and the static absolute pressure of the ambient air. In colloquial language, this is usually referred to as „pressure“.

„ANR“ means that the specification applies to standard reference atmosphere (at a pressure of 0.1MPa (1bar), a temperature of 20°C and a relative air humidity of 65%).

In this User Manual, the term „smoke aspiration system“ refers both to

- ◆ the actual evaluation unit of a smoke aspiration system as well as sometimes also to
- ◆ the combination of the essential components of which a smoke aspiration system consists, namely, the evaluation unit, the smoke aspiration detector, the sensor pipe network and sometimes the compressed-air supply, etc.

In the context it is always clear what is meant in the particular case.

The fire detection control panel is also abbreviated as „FDCP“.

„PLC“ is the abbreviation for programmable logic controller.

Further abbreviations that are not familiar in everyday usage are avoided in this User Manual.

1.5 Important tips

Fire detection systems and their components must always be planned, installed and put into operation by specialists who are trained on a continuous basis. The specific specialist training on the functions of the smoke aspiration systems must be provided by the respective manufacturer or by persons expressly authorized by the manufacturer for this purpose. Since the Purging unit will be integrated directly into the sensor pipe network of the smoke aspiration system, the guidelines of

the manufacturer of the smoke aspiration system, with regard to the construction and length of the pipe network, must be observed.

The devices that are used in addition to the smoke aspiration system, such as the fire detection control panel, the power supply, etc., are only mentioned as examples in this User Manual. The present manual does not provide any information concerning the expert planning or design of a fire detection system. It replaces neither the installer's required technical qualification nor his or her specific training.



Pay attention to the danger notices given on page 3.



Beware of static charges! The electronic components used in the Automatic Purging Units Series F-BO-AFE70-2 can be destroyed by static charges when the device is open. Before and during the work being performed on printed circuit boards, static charges from your body must be reliably discharged by touching an earthed piece of metal.

1.6 Scope of delivery

The Automatic Purging Units Series F-BO-AFE70-2 are assembled at the factory and supplied 100% function-tested. Only the pipe connecting parts (as well as in the case of the F-BO-AFE70-1 the push-in fitting for the compressed-air connection) have been enclosed for reasons of safe transport and still have to be installed. Please check the delivery for completeness and transport damage before installing the equipment.

The delivery scope of the Automatic Purging Unit Series F-BO-AFE70-2 includes:

- ◆ the valve block (with flange-mounted solenoid valve) that has been mounted on the bottom plate and has been completely assembled and tested, including the mounted control board AFS70-1, with protection cover (i.e., the housing) and cover.
- ◆ two 25mm push-in fittings for the connection to the sensor pipe network
- ◆ two pipe nipples G3/4"×34mm
- ◆ two plastic gaskets Ø32mm×10mm
- ◆ this User Manual
- ◆ an end-of-line resistor 5.6kOhm (for the line-monitoring of the fault output of the evaluation unit of the smoke aspiration system)
- ◆ mounting material (three screws and three 6mm plugs for wall mounting) as well as small parts
- ◆ three cable ties
- ◆ transport packaging
- ◆ a 10mm push-in fitting for the connection to the compressed air network (only F-BO-AFE70-2-1).



The Purging unit weighs approx. 3.2kg – the sturdy transport packaging has been designed to avoid transport damage to any part. If the packaging has been damaged, you must inspect the Purging unit especially thoroughly.

2 Manner of operation of a Purging unit

Typical structure of a system, consisting of fire detection control panel, smoke aspiration system, Purging unit, compressed-air supply and sensor pipe network.

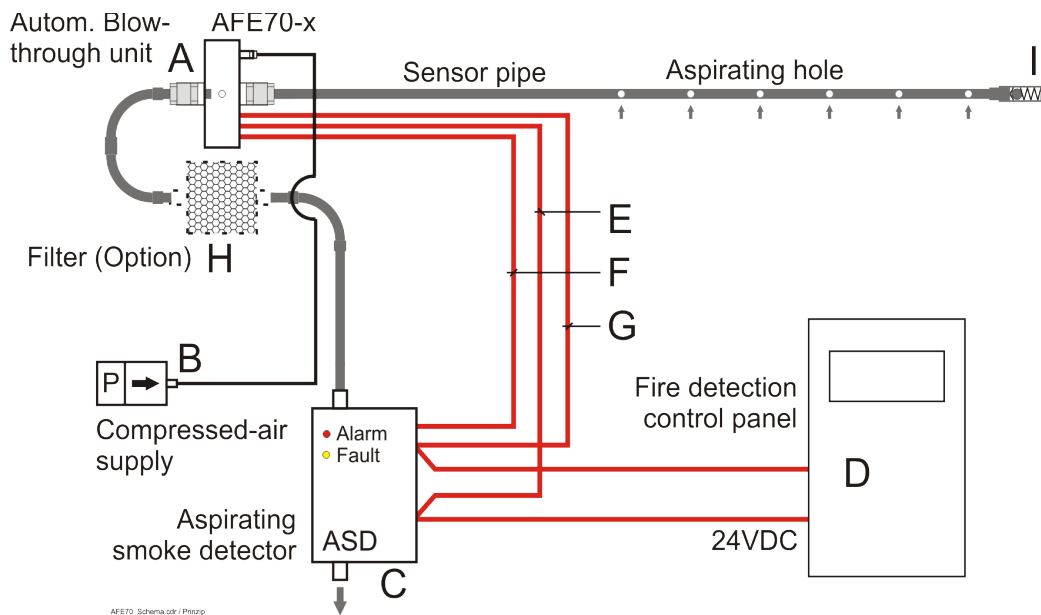

Fig. 2: Depiction of the structure of a system with an Automatic Purging Unit F-BO-AFE70-2 as well as the required components and connections

A ... Automatic Purging Unit F-BO-AFE70-2

B ... Compressed-air supply

C ... Smoke aspiration system; in the above diagram a smoke aspiration system with one pipe is shown, note that for each pipe network one Purging unit is needed.

D ... Fire detection control panel

E ... Power supply line. Both the Purging unit as well as the smoke aspiration system must be supplied with 24VDC.

F ... Transmission of the fault message of the smoke aspiration system to the F-BO-AFE70-2

G ... Transmission of the fault of the smoke aspiration system and of the fire alarm to the fire detection control panel. The connection can be established – as shown in the figure above – by means of a conventional line or via loop modules.

H ... Air filter (optional), which should be located before the Purging unit. As a result, on the one hand the Purging unit is protected against contamination, and on the other hand every Purging process also cleans the filter. If this is not possible (for example, because the filter case is not pressure-resistant), the filter must be located between the Purging unit and the smoke aspiration system.

I ... Check valve

2.1 General

Smoke aspiration systems use a low negative pressure to continuously sample air through aspiration holes of a sensor pipe network that is laid in a room or building, and direct them to a central measuring element (the evaluation unit) in order to examine the sample for various characteristics (e.g., the smoke concentration).

Over the operating time, continuously aspirating the ambient medium through the relatively small aspiration holes and a pipe network with a relatively small cross-sectional area leads to an accumulation of contaminations which can change the aspirated air flow and can even result in the measurement failing completely. In order to prevent this contamination, contaminated pipe networks and filter systems must be regularly cleaned („blown off“) by means of compressed air.

For this purpose, clean compressed air is manually or automatically led into the pipe network and/or the filter system at intervals. In order to protect the evaluation unit of the smoke aspiration system against damage caused by exposure to compressed air, in conventional Purging units first a valve isolates the evaluation unit from the pipe network, and then compressed air is led into the pipe network through a second valve that is connected to a T-piece.

In the case of conventional automatic Purging units, the solenoid valve which isolates the evaluation unit is dimensioned large in order to ensure for the normal aspiration mode of the smoke aspiration system that the loss of flow is low when the valve is open. The valve for the activation of the compressed-air supply is usually a solenoid valve that is dimensioned much smaller. The process of controlling these valves is usually carried out by a commercial programmable logic controller.

2.2 Characteristic features of the Automatic Purging Units Series F-BO-AFE70-2

In contrast to the structure of conventional Purging units, the Automatic Purging Units Series F-BO-AFE70-2 only need one (built-in) solenoid valve; furthermore, thanks to their thoughtful design, the Automatic Purging Units Series F-BO-AFE70-2 ensure completely unhindered air flow from the sensor pipe network through the Purging unit to the evaluation unit of the smoke aspiration system. The unit is controlled by an integrated control board which has been developed for this special task and which replaces the PLC that is normally used.

Thanks to the use of high-quality materials and the high-precision processing, the Automatic Purging Units Series F-BO-AFE70-2 are designed to ensure flawless operation for many years.

The trouble-free operation can be affected by various environmental influences, such as temperature, humidity and air that is polluted by gases and aerosols, which can cause increased need for maintenance and reduce the life span due to wear and tear or contamination.

The following features distinguish the Automatic Purging Units Series F-BO-AFE70-2:

- ◆ 6 Purging programs, each with short or long Purging cycle
- ◆ they can be manually controlled by means of an external push-button
- ◆ internal clock for up to 6 daily timed, preventive Purging processes
- ◆ automatic start if fault message is received from smoke aspiration system
- ◆ remote-controlled start (e.g., based on external calendar of factory or office hours)
- ◆ if there are several F-BO-AFE70-2's, a time delay can be used so as not to stress the compressed-air system
- ◆ master-slave mode with actuation of one or more „slaves“
- ◆ monitoring of the supply voltage
- ◆ they can be used in a wide pressure range (F-BO-AFE70-2-1 up to 1.0 MPa (10bar), F-BO-AFE70-2-2 up to 0.7MPa (7bar))
- ◆ they are prepared for connection to all usual fire detection control panels, either via conventional lines or via loop modules.

2.3 Usual manner of operation of the Automatic Purging Units Series F-BO-AFE70-2

In the quiescent state the Purging unit as well as the smoke aspiration system are in normal operation; the status LED of the Purging unit illuminates green.

If the smoke aspiration system that is connected to the Purging unit detects a disturbance of the air flow (e.g., because one or more aspiration hole(s) of the sensor pipe network is/are clogged with dust), it reports this to the Purging unit as fault. The Purging unit detects the fault, delays its transmission to the fire detection control panel and starts an automatic Purging process in order to remove the clogging. Depending on the parameterisation, a Purging process can consist of 3 activations of the solenoid valve, each with a duration of 3 seconds, or of 5 activations, each with a duration of 5 seconds. Every activation of the solenoid valve for the Purging process is clearly audible, and in addition it is indicated by the status LED which illuminates alternately green and red.

After conclusion of the Purging process, an observation period of 60 seconds follows. The fault which still exists but has not yet been transmitted to the fire detection control panel is indicated by the status LED that is blinking yellow.

If the clogging has been removed by the Purging process, the smoke aspiration system resets the air flow fault within the observation period and the Purging unit as well as the smoke aspiration system will resume normal operation.

If the clogging has not been removed by the Purging process, the smoke aspiration system will remain in the fault condition beyond the observation period, and after expiry of the observation period the Purging unit will transmit the fault to the fire detection control panel. This condition is indicated on the Purging unit by the status LED which illuminates in yellow.

The integrated clock of the Purging unit starts timed automatic Purging processes daily at determined times, provided that this feature has been prepared by the installer of the system. These Purging processes are started independently of the fault message of the smoke aspiration system and serve to preventively remove contaminations from the sensor pipe network and the aspiration holes.

Manual Purging activations can be carried out at any time by pressing the external push-button „Manual activation“, provided that this feature has been prepared by the installer of the system.

The complete overview of the displaying and operating possibilities of the Automatic Purging Units Series F-BO-AFE70-2 can be found in the next Chapter 3: „Displaying of the operating conditions and operation“.

3 Displaying of the operating conditions and operation

This chapter describes how the individual operating conditions of the Purging unit are indicated and explains the respective operational features.

3.1 Operating conditions indicated by the status LED

The control board of the Purging unit continuously checks the status and indicates it in red, yellow and green, by means of the status LED.

The conditions that are indicated by the status LED are explained below in Table 2.



If the status LED is dark it is very likely that the Purging unit experiences a power failure or, if it has been proven that the supply voltage is available, the componentry itself experiences a fault. In any case you must assume that the Purging unit is inoperable. The fault must be removed as soon as possible.

Condition of the status LED G = green, R = red Y = yellow	Condition of the control board / response time / effect / removal
<div style="background-color: green; color: black; text-align: center; padding: 2px;">G</div> illuminates green	Condition: Normal condition Response time: Immediately Effect: Componentry is in normal operation Removal: Not necessary
<div style="display: flex; justify-content: space-around; align-items: center;"> <div style="width: 10px; height: 10px; background-color: green; margin-right: 5px;"></div> <div style="width: 10px; height: 10px; background-color: green; margin-right: 5px;"></div> <div style="width: 10px; height: 10px; background-color: green; margin-right: 5px;"></div> <div style="width: 10px; height: 10px; background-color: green;"></div> </div> ↑=G flashing green	Condition: No valid Purging program selected Response time: Immediately Effect: The componentry is all right, however it will not carry out an automatic Purging process. HINT: Switch position 0 allows you to set the time, switch position F allows you to set the device number. Removal: Select a valid Purging program.
<div style="display: flex; justify-content: space-around; align-items: center;"> <div style="width: 10px; height: 10px; background-color: green; margin-right: 2px;"></div> <div style="width: 10px; height: 10px; background-color: red; margin-right: 2px;"></div> <div style="width: 10px; height: 10px; background-color: green; margin-right: 2px;"></div> <div style="width: 10px; height: 10px; background-color: red; margin-right: 2px;"></div> <div style="width: 10px; height: 10px; background-color: green; margin-right: 2px;"></div> <div style="width: 10px; height: 10px; background-color: red; margin-right: 2px;"></div> <div style="width: 10px; height: 10px; background-color: green;"></div> </div> alternately green and red	Condition: The solenoid valve has been activated. Response time: Immediately Effect: The Purging process is currently running. Removal: Not necessary
<div style="display: flex; justify-content: space-around; align-items: center;"> <div style="width: 10px; height: 10px; background-color: yellow; margin-right: 5px;"></div> <div style="width: 10px; height: 10px; background-color: yellow; margin-right: 5px;"></div> <div style="width: 10px; height: 10px; background-color: yellow; margin-right: 5px;"></div> <div style="width: 10px; height: 10px; background-color: yellow;"></div> </div> blinking yellow	Condition: Either the evaluation unit of the smoke aspiration system reports a fault, or a wire breakage on the connection line from the Purging unit (terminals 3 and 4) to the evaluation unit of the smoke aspiration system has been detected; the fault has not yet been transmitted to the fire detection control panel. Response time: Immediately Effect: If the smoke aspiration system reports a fault, the selected Purging process will be started, 60 seconds after the end of the Purging process a still existing fault message will be transmitted to the fire detection control panel. The smoke aspiration system could be partly or completely out of order and therefore must be checked. If the connection line is broken, this will be evaluated like a fault message from the evaluation unit of the smoke aspiration system. Removal: If there is no fault of the smoke aspiration system, the connection line must be checked for freedom from faults.



Condition of the status LED G = green, R = red Y = yellow	Condition of the control board / response time / effect / removal
 flashing yellow	Condition: A short circuit on the connection line to the fault contact of the smoke aspiration system has been detected. Response time: Immediately Effect: If the Purging unit is synchronised by an external timer and the short circuit exists for approx. 60 seconds, the internal clock will be synchronised to 00:00. If the short circuit exists for less than 50 seconds, this will be indicated by the status LED, but apart from that it will not be evaluated. If the short circuit exists for more than 70 seconds, this will be evaluated as fault, the condition of the status LED will change to illuminating yellow and the fault message will be transmitted to the fire detection control panel. Removal: If the time has not been synchronised, the connection line must be checked.
 illuminates yellow	Condition: There is a fault which has been transmitted to the fire detection control panel as a fault. Response time: Immediately Effect: The fault is indicated on the fire detection control panel. Maybe the smoke aspiration system is partly or completely out of order and must be checked. Removal: If an air flow fault of the smoke aspiration system exists, further manual Purging processes should be carried out in order to remove the clogging (see on page 30 in Chapter 8.3: „Location of the display and operating elements and terminals on the control board of the Automatic Purging Units Series F-BO-AFE70-2“ as well as on page 31 in Chapter 8.4.1.1: „Push-button „Manual activation““). If there is another fault, it must be removed in the smoke aspiration system. If there is no fault of the smoke aspiration system, the connection line must be checked for freedom from faults.

Table 2: Possible conditions of the componentry status display

3.2 Operation by the user

If a valid Purging program has been set on the Purging unit, the unit operates in the automatic mode and the status LED indicates the current condition.

In this case the Purging processes will be carried out automatically. If additional Purging processes are needed, you can carry them out by pressing the external push-button „Manual activation“, provided that this feature has been prepared by the installer of the system. In this case, the compressed air will be blown into the pipe network for as long as the push-button is being pressed, but the maximum duration for one press of the push-button is limited to 2 minutes.

3.3 Operation by the installer

If a valid Purging program (Purging program „1“ ... „C“) has been set on the Purging unit, additional Purging processes can be started manually.

A manual Purging process can be started by briefly pressing the button TA1; depending on the Purging program that has been set with the rotary switch „Purging program“ SW1, this will carry out a long or short Purging process.



The button TA1 will only be accessible after removing the cover (see Fig. 4 on page 20).

4 Pneumatic components – dimensioning

4.1 Purging unit

The geometry of the sensor pipe and the number and size of the aspiration holes depends on the size and geometry of the room as well as the technical possibilities of the smoke aspiration system used. Thanks to the special construction of the Automatic Purging Units Series F-BO-AFE70-2, they do not cause an additional air resistance in the sensor piping that is worth mentioning, and therefore they do not have to be taken into consideration when dimensioning the pipe network.



You must not exceed the values specified in the project planning guidelines of the smoke aspiration system. In particular, make sure that the project planning is carried out in accordance with the current version of the European Standard EN 54-20.

Through intensive tests and experiments, the recommended values for dimensioning that are stated below, have been established. Please note that the specified values are only approximate values because a huge number of components (the length and the geometry of the pipe, the position of the aspiration holes along the piping, the opening pressure of a check valve that may exist, etc.) affect the Purging process. Therefore you can only make sure that the Purging unit is working properly by carrying out a final test on the individual system.

First calculate the total aperture area of the aspiration holes that exist in the pipe network. In order to keep the calculation simple, the table below shows the area of a circular hole, depending on its diameter.

Diameter [mm]	Area [mm ²]	Diameter [mm]	Area [mm ²]	Diameter [mm]	Area [mm ²]
2.00	3.15	4.00	12.57	6.00	28.28
2.10	3.47	4.10	13.21	6.10	29.23
2.20	3.81	4.20	13.86	6.20	30.20
2.30	4.16	4.30	14.53	6.30	31.18
2.40	4.53	4.40	15.21	6.40	32.17
2.50	4.91	4.50	15.91	6.50	33.19
2.60	5.31	4.60	16.62	6.60	34.22
2.70	5.73	4.70	17.35	6.70	35.26
2.80	6.16	4.80	18.10	6.80	36.32
2.90	6.61	4.90	18.86	6.90	37.40
3.00	7.07	5.00	19.64	7.00	38.49
3.10	7.55	5.10	20.43	7.10	39.60
3.20	8.05	5.20	21.24	7.20	40.72
3.30	8.56	5.30	22.07	7.30	41.86
3.40	9.08	5.40	22.91	7.40	43.01
3.50	9.63	5.50	23.76	7.50	44.18
3.60	10.18	5.60	24.64	7.60	45.37
3.70	10.76	5.70	25.52	7.70	46.57
3.80	11.35	5.80	26.43	7.80	47.79
3.90	11.95	5.90	27.34	7.90	49.02

Table 3: Calculation aid for the determination of the total aperture area of the aspiration holes in the sensor piping; add up the stated values for the holes in the piping that is to be connected to the Purging unit.

The tables below show the operation limits of the Automatic Purging Units F-BO-AFE70-1 and F-BO-AFE70-2, depending on the input overpressure during the Purging process and on the sum of the aperture area of the aspiration holes of the piping that is connected to the Purging unit.



The data is based on a DN25 pipe network that has been realised as straight branch, and on a check valve with an opening pressure of 25kPa (0.25bar) that has been installed at the end of the pipe network. A safety factor has been added to the data and therefore it can be regarded as approximate value for normal system configurations, but the proper functioning of the respective system must always be verified in a test!



During the Purging process, the input overpressure decreases, depending on the quality of the compressed-air supply and the air volume that is consumed. The input overpressure value listed in the table is the **value when air is being consumed**, i.e., the decreased value!

Eingangstiberdruck input overpressure	1.00MPa (10bar)	AFE70-1 (1000L)	AFE70-1 (1000L)	AFE70-1 (1000L)	AFE70-1 (1000L)	AFE70-1 (1000L)	AFE70-1 (1000L)	AFE70-1 (1000L)	AFE70-1 (1000L)	AFE70-1 (1000L)
	0.90MPa (9bar)	AFE70-1 (1000L)	AFE70-1 (1000L)	AFE70-1 (1000L)	AFE70-1 (1000L)	AFE70-1 (1000L)	AFE70-1 (1000L)	AFE70-1 (1000L)	AFE70-1 (1000L)	-
	0.80MPa (8bar)	AFE70-1 (1000L)	AFE70-1 (1000L)	AFE70-1 (1000L)	AFE70-1 (1000L)	AFE70-1 (1000L)	AFE70-1 (1000L)	AFE70-1 (1000L)	-	-
	0.70MPa (7bar)	AFE70-1 (1000L)	AFE70-1 (1000L)	AFE70-1 (1000L)	AFE70-1 (1000L)	AFE70-1 (1000L)	AFE70-1 (1000L)	-	-	-
	0.60MPa (6bar)	AFE70-1 (1000L)	AFE70-1 (1000L)	AFE70-1 (1000L)	AFE70-1 (1000L)	-	-	-	-	-
	0.50MPa (5bar)	AFE70-1 (1000L)	AFE70-1 (1000L)	-	-	-	-	-	-	-
	0.40MPa (4bar)	-	-	-	-	-	-	-	-	-
	0.30MPa (3bar)	-	-	-	-	-	-	-	-	-
		40mm ²	50mm ²	60mm ²	70mm ²	80mm ²	90mm ²	100mm ²	110mm ²	120mm ²
		gesamte Öffnungsfläche total aperture area								

Table 4: Operation limits of the Automatic Purging Unit F-BO-AFE70-1, depending on the input pressure that is available during the Purging process („input overpressure“) and the sum of the aperture areas of the sensor piping that is to be connected to the Purging unit („total aperture area“).

Eingangstiberdruck input overpressure	1.00MPa (10bar)	-	-	-	-	-	-	-	-	-
	0.90MPa (9bar)	-	-	-	-	-	-	-	-	-
	0.80MPa (8bar)	-	-	-	-	-	-	-	-	-
	0.70MPa (7bar)	AFE70-2 (3500L)	AFE70-2 (3500L)	AFE70-2 (3500L)	AFE70-2 (3500L)	AFE70-2 (3500L)	AFE70-2 (3500L)	AFE70-2 (3500L)	AFE70-2 (3500L)	AFE70-2 (3500L)
	0.60MPa (6bar)	AFE70-2 (3500L)	AFE70-2 (3500L)	AFE70-2 (3500L)	AFE70-2 (3500L)	AFE70-2 (3500L)	AFE70-2 (3500L)	AFE70-2 (3500L)	AFE70-2 (3500L)	AFE70-2 (3500L)
	0.50MPa (5bar)	AFE70-2 (3500L)	AFE70-2 (3500L)	AFE70-2 (3500L)	AFE70-2 (3500L)	AFE70-2 (3500L)	AFE70-2 (3500L)	AFE70-2 (3500L)	AFE70-2 (3500L)	-
	0.40MPa (4bar)	AFE70-2 (3500L)	AFE70-2 (3500L)	AFE70-2 (3500L)	AFE70-2 (3500L)	AFE70-2 (3500L)	-	-	-	-
	0.30MPa (3bar)	AFE70-2 (3500L)	AFE70-2 (3500L)	AFE70-2 (3500L)	-	-	-	-	-	-
		40mm ²	50mm ²	60mm ²	70mm ²	80mm ²	90mm ²	100mm ²	110mm ²	120mm ²
		gesamte Öffnungsfläche total aperture area								

Table 5: Operation limits of the Automatic Purging Unit F-BO-AFE70-2, depending on the input pressure that is available during the Purging process („input overpressure“) and the sum of the aperture areas of the sensor piping that is to be connected to the Purging unit („total aperture area“). The Automatic Purging Unit F-BO-AFE70-2 must not be operated with input overpressures of more than 0.7MPa (7bar)!



The Automatic Purging Units F-BO-AFE70-2 still work perfectly at and below an input overpressure of 0.1MPa (1bar), but perhaps the resulting pressure built up in the pipe network will not suffice to open the check valve and to clean the pipe network completely.



If the sum of the area of the aspiration holes of the sensor piping exceeds the specified values, branches can also be blown off, by means of the master-slave mode (see from page 32 onwards in Chapter 8.4.2: „Connection of Purging units in the master-slave mode“), through separate Automatic Purging Units Series F-BO-AFE70-2. This also applies analogously to the areas marked with „-“ in Tables 4 and 5.

4.2 Compressed-air supply

The required size of the air vessel as well as the air delivery volume of the compressed-air supply essentially depend on the following factors:

- ◆ positive operating pressure of the compressed-air supply (air vessel overpressure)
- ◆ chosen type of the Purging unit
- ◆ chosen input overpressure of the Purging unit

- ◆ total opening time of the solenoid valve during the Purging process.

During the Purging process the Automatic Purging Units Series F-BO-AFE70-2 briefly need a very large amount of air which is withdrawn from the air vessel of the compressed-air supply. The air output capacity of a compressor is only of secondary importance for the dimensioning of the compressed-air supply of the Purging unit because usually the time between two Purging processes is very long and therefore the compressor has sufficient time for charging the air vessel. Therefore, only the dimensioning of the air vessel is dealt with below.

Tables 6 and 7 contain approximate values for the calculation of the minimum size of the air vessel of the compressed-air system, depending on the air vessel overpressure and the chosen input overpressure of the respective Purging unit. The results of the tables are given in litres per second of operation of the solenoid valve, and therefore they still have to be multiplied by the solenoid valve's operation time during a Purging process, in order to obtain the size of the air vessel.



The prerequisite for the validity of the tables in this chapter is a constant input overpressure of the Purging unit during the Purging process; to ensure this an appropriately dimensioned pressure-limiting valve is required.



The calculation of the stated values is based on a pipe between air vessel and Purging unit that is very short and has a low velocity loss. Therefore, if the distances are large, see to it that the compressed-air supply pipe is generously dimensioned in order to keep the loss in pressure low.

In order to estimate the required air vessel size, proceed as follows:

First determine on the basis of the specifications in Chapter 4.1 the required type of Purging unit as well as the required input overpressure of the Purging unit.

Then choose the appropriate table for the type of Purging unit used; Table 6 applies to the F-BO-AFE70-1, Table 7 to the F-BO-AFE70-2.

Now use the table and determine the air vessel's required sub volume (in litres per second of the Purging process) at the intersection of the Purging unit's required input overpressure and the available air vessel overpressure. For the required total air vessel volume you have to multiply the determined size by the solenoid valve's planned total opening time during the Purging process.

An example should explain the approach:

For your system you need an F-BO-AFE70-2 with an input overpressure of at least 0.5MPa (5 bar). Furthermore, your planned air vessel overpressure of the compressor is 1.0MPa (10bar).

To determine the size of the air vessel for an Automatic Purging Unit F-BO-AFE70-2-2 you also use Table 7. The Purging unit's required input overpressure of 0.5MPa (5bar) and the air vessel overpressure of the compressor of 1.0MPa (10bar) result in an air vessel sub volume of 9.4 litres per second of opened solenoid valve.

Depending on the Purging process that is to be set according to Chapter 8.5.1 in the course of commissioning, the solenoid valve's total opening time during the Purging process amounts to $3 \times 3 = 9$ seconds (for the short Purging process) or $5 \times 5 = 25$ seconds (for the long Purging process).

So in the case of the short Purging process and an air vessel overpressure of 1.0MPa (10bar), an air vessel volume of at least $9.4 \times 9 = 84.6$ litres is needed, in the case of the long Purging process an air vessel volume of at least $9.4 \times 25 = 235$ litres is needed.

Kesselüberdruck air vessel overpressure	1.2MPa (12bar)	0.4	0.6	0.9	1.3	1.8	2.4	3.4	4.8	7.3	11.9
	1.1MPa (11bar)	0.4	0.7	1.0	1.5	2.0	2.8	4.2	6.4	10.9	23.7
	1.0MPa (10bar)	0.5	0.7	1.2	1.7	2.4	3.5	5.6	9.6	21.7	-
	0.9MPa (9bar)	0.5	0.8	1.4	2.0	3.0	4.7	8.4	19.2	-	-
	0.8MPa (8bar)	0.6	1.0	1.6	2.5	4.0	7.0	16.7	-	-	-
	0.7MPa (7bar)	0.7	1.1	2.0	3.4	6.0	14.0	-	-	-	-
	0.6MPa (6bar)	0.8	1.4	2.7	5.0	12.0	-	-	-	-	-
	0.5MPa (5bar)	1.0	1.9	4.0	10.0	-	-	-	-	-	-
	0.4MPa (4bar)	1.3	2.8	8.0	-	-	-	-	-	-	-
	0.3MPa (3bar)	2.0	5.5	-	-	-	-	-	-	-	-
	0.2MPa (2bar)	3.9	-	-	-	-	-	-	-	-	-
	0.1MPa (1bar)	-	-	-	-	-	-	-	-	-	-
		0.1MPa (1bar)	0.2MPa (2bar)	0.3MPa (3bar)	0.4MPa (4bar)	0.5MPa (5bar)	0.6MPa (6bar)	0.7MPa (7bar)	0.8MPa (8bar)	0.9MPa (9bar)	1.0MPa (10bar)
	Eingangüberdruck AFE70-1 input overpressure AFE70-1										

Table 6: Estimate of the minimum size of the air vessel, depending on the air vessel overpressure and the required input overpressure of the Automatic Purging Unit F-BO-AFE70-1. The values are given in litres per second of operation of the solenoid valve.

Kesselüberdruck air vessel overpressure	1.2MPa (12bar)	1.4	2.4	3.4	4.8	6.7	9.2	12.4	-	-	-
	1.1MPa (11bar)	1.5	2.6	3.8	5.5	7.8	11.0	15.5	-	-	-
	1.0MPa (10bar)	1.7	3.0	4.3	6.4	9.4	13.8	20.6	-	-	-
	0.9MPa (9bar)	1.9	3.4	5.0	7.7	11.7	18.4	30.9	-	-	-
	0.8MPa (8bar)	2.2	3.9	6.0	9.6	15.6	27.5	61.7	-	-	-
	0.7MPa (7bar)	2.5	4.7	7.5	12.8	23.4	55.0	-	-	-	-
	0.6MPa (6bar)	3.0	5.9	10.0	19.2	46.7	-	-	-	-	-
	0.5MPa (5bar)	3.8	7.8	15.0	38.4	-	-	-	-	-	-
	0.4MPa (4bar)	5.0	11.7	30.0	-	-	-	-	-	-	-
	0.3MPa (3bar)	7.5	23.4	-	-	-	-	-	-	-	-
	0.2MPa (2bar)	15.0	-	-	-	-	-	-	-	-	-
	0.1MPa (1bar)	-	-	-	-	-	-	-	-	-	-
		0.1MPa (1bar)	0.2MPa (2bar)	0.3MPa (3bar)	0.4MPa (4bar)	0.5MPa (5bar)	0.6MPa (6bar)	0.7MPa (7bar)	0.8MPa (8bar)	0.9MPa (9bar)	1.0MPa (10bar)
	Eingangüberdruck AFE70-2 input overpressure AFE70-2										

Table 7: Estimate of the minimum size of the air vessel, depending on the air vessel overpressure and the required input overpressure of the Automatic Purging Unit F-BO-AFE70-2. The values are given in litres per second of operation of the solenoid valve.

5 Final assembly, mechanical structure and dimensions

5.1 Final assembly

For reasons of safe transport, the pipe connecting components, and in the case of the F-BO-AFE70-1 the push-in fitting for the connection to the compressed air network as well, are enclosed and still have to be installed.

Figure 4 gives an overview of the structure of a Purging unit after final assembly.

In order to assemble the device, proceed as follows:

Remove the two M3 screws from the cover and lift the cover of the Purging unit.

Remove the protective covers from the openings of the housing.

Screw a pipe nipple G3/4"×34mm by hand into the thread of the 25mm push-in fitting as far as it will go and completely push the plastic gasket Ø32mm×10mm onto the pipe nipple.

Now screw the part of the pipe nipple's thread that protrudes from the plastic gasket by hand into one of the two fitting threads of the Purging unit's body as far as it will go (see Figure 3).

Use a wrench of the right size (wrench size 32mm) to turn the 25mm push-in fitting by approximately another 30° until it seats tightly and seals perfectly.

Repeat the procedure described above for the other side of the Purging unit.

By carrying out this step, the final assembly of the F-BO-AFE70-2 has been completed. In the case of the F-BO-AFE70-1, the 10mm push-in fitting for the connection to the compressed air network still has to be installed. Screw the push-in fitting by hand into the aluminium body's G3/8" threaded hole to which it belongs and tighten it with a suitable wrench (wrench size 17mm).



It must be ensured that after final installation of the Purging unit, no push-in fitting can be loosened by hand, and that all push-in fittings are perfectly sealed. Therefore, check the tight seat of the push-in fittings after final assembly and prior to commissioning.

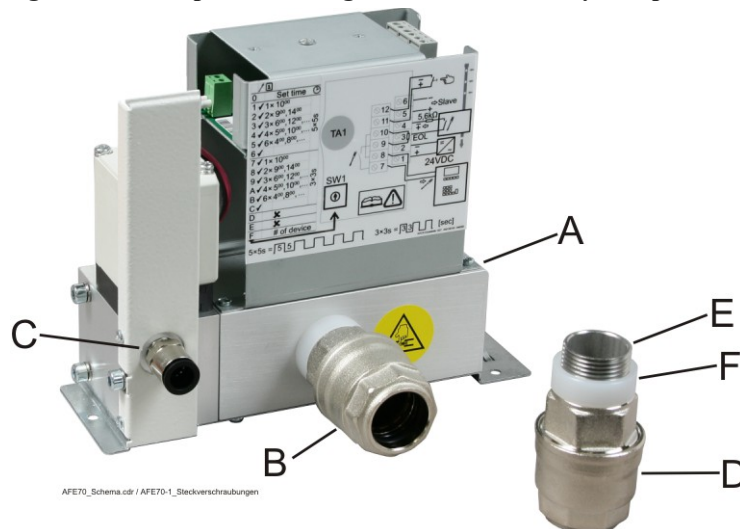

Fig. 3: View of the F-BO-AFE70-1 (A) without cover, with a 25mm push-in fitting (B) completely screwed in, as well as the 10mm push-in fitting (C) that has been screwed in. The second 25mm push-in fitting (D) that has already been prepared for screwing in, with G3/4" pipe nipple (E) screwed in and gasket (F) attached, can be seen in the foreground.

5.2 Mechanical structure

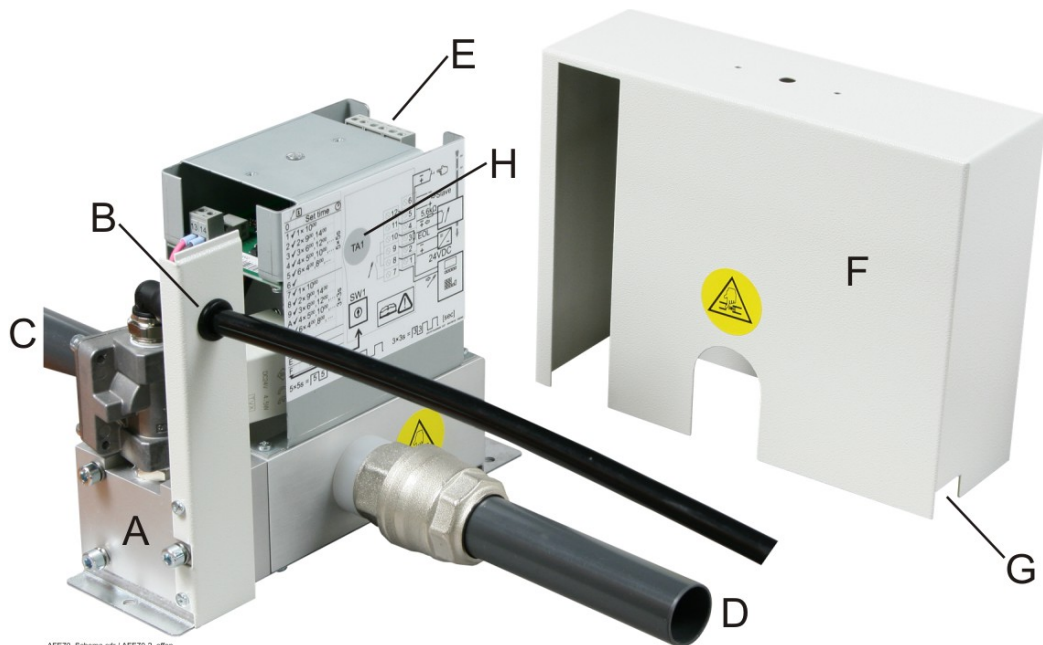

Fig. 4: View of an Automatic Purging Unit F-BO-AFE70-2 with cover taken off

- A ... Valve block*
- B ... Compressed-air connection*
- C ... Sensor pipe to the monitored area*
- D ... Sensor pipe to the smoke aspiration system*
- E ... Control board AFS70-1*
- F ... Cover of the Purging unit*
- G ... Opening for the cable entry*
- H ... Button TA1*

5.3 Dimensions

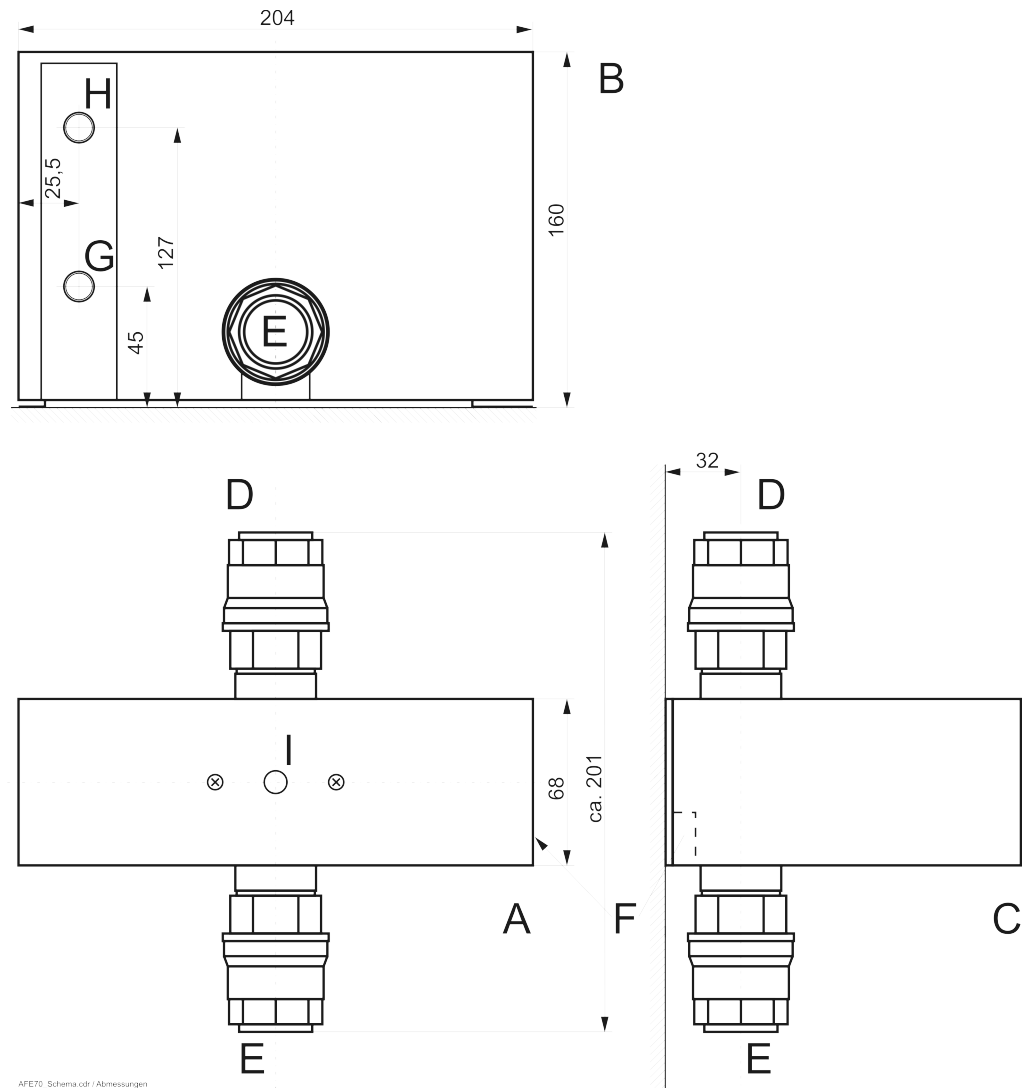

Fig. 5: Dimensions of the Automatic Purging Units Series F-BO-AFE70-2

A ... Front view

B ... View from below

C ... View from the left side

D ... Sensor pipe to the monitored area

E ... Sensor pipe to the smoke aspiration system

F ... Position of the opening for the cable entry

G ... Compressed-air connection F-BO-AFE70-1

H ... Compressed-air connection F-BO-AFE70-2

I ... Status LED

6 Safety devices

By installing the Automatic Purging Unit Series AFE70 in the customer's pipe network, and through the connection to the other components also provided by the customer, namely the smoke aspiration system, the fire detection control panel, the electrical power supply as well as the compressed-air supply, a machine in the sense of the Directive 2006/42/EC is created.

Therefore the adherence to this directive must be ensured during the whole installation; therefore corresponding measures have to be taken which depend on the system construction, the installed components as well as the use of the building, and which can also exceed the minimum requirements listed below. Therefore a corresponding danger evaluation is required in any case.

The following basic minimum requirements must always be fulfilled in any case and at any time:

- ◆ A protection against contact with the movable valve piston of the purging unit must be in place; this requirement is fulfilled if both 25mm push-in fittings have been installed as described in Chapter 5.1: „Final assembly“ and suitable pipes of the customer's pipe system have been inserted in such a way that it is not possible to enter and touch the valve piston without a tool, also compare Chapter 7.2: „Connection to the sensor pipe and to the evaluation unit of the smoke aspiration system“ in this regard.
- ◆ The possibility that the compressed air that is introduced into the pipe system during the purging process can eject parts which can cause injuries or damage to property, must have been prevented altogether. This can be done, for example, by altogether preventing such parts from entering the compressed-air system or the sensor piping, or by making sure that at the time of the purging process nobody can stay in the danger zone, or by implementing other suitable protective measures (e.g., deflectors) in the system.
- ◆ All parts that will be pressurised during operation (for example, pipes, fittings, valves, hoses, pressure regulators and filters) must have been approved for the application of compressed air within the pressure range that is to be expected.
- ◆ A device must be installed by means of which the system can be easily shut down both in the event of an emergency as well as during normal operation. This is ensured, for example, if the compressed-air supply to the Automatic Purging Unit Series AFE70 can be interrupted easily and quickly by means of a hand-actuated pneumatic valve. This valve must be freely accessible and has to be appropriately labelled or signposted with „EMERGENCY STOP“.

If, in spite of all the safety precautions and protective measures that have been taken, unavoidable risks still exist, the necessary warnings and warning devices have to be put up.



A failure to meet the requirements described here can have serious consequences for life, limb and property; therefore make sure that all required devices are in place and function flawlessly.

7 Mounting and connection of pneumatic components

This chapter describes the mounting of the Purging unit, the connection to the sensor pipe network as well as the smoke aspiration system and the compressed-air connection.



Pay attention to the danger notices given on page 3.



Beware of static charges! The electronic components used in the Automatic Purging Units Series F-BO-AFE70-2 can be destroyed by static charges when the device is open. Before and during the work being performed on printed circuit boards, static charges from your body must be reliably discharged by touching an earthed piece of metal.

7.1 Location of installation

The Automatic Purging Unit Series F-BO-AFE70-2 must be installed in a clean and dry room on a stable wall surface. The room temperature in the immediate vicinity of the Purging unit must range between +5°C and +50°C, the relative humidity of the air must not exceed 95% at 40°C.



Bear in mind that the life span of the components may be reduced by high temperature and humidity. Therefore, it is recommended to install the Purging unit in an environment with a normal indoor climate (i.e., up to +40°C), if it is possible.

The pipe connection between the Automatic Purging Unit Series F-BO-AFE70-2 and the evaluation unit of the smoke aspiration system should be as short as possible. Please note that this connecting piece is not cleaned during the „Purging process“!

7.1.1 Permissible mounting positions

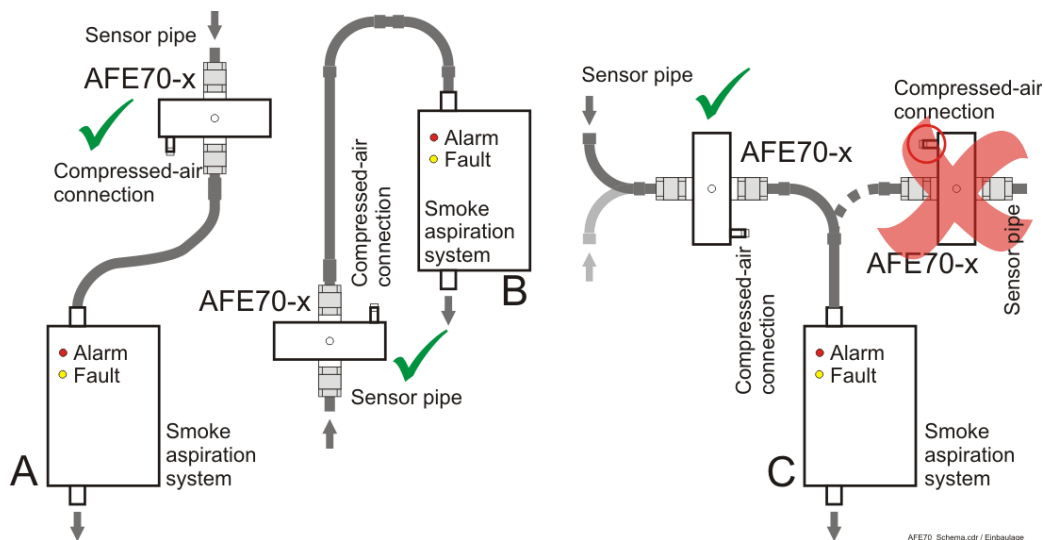

Fig. 6: Schematic illustration of the permissible wall mounting positions of the Automatic Purging Units Series F-BO-AFE70-2 together with the evaluation unit and the sensor pipe of the smoke aspiration system.

A ... Mounting position with downward air flow in the direction of aspiration (compressed-air-connection at the bottom)

B ... Mounting position with upward air flow in the direction of aspiration (compressed-air-connection at the top)

C ... Mounting position with air flow from the left to the right in the direction of aspiration (compressed air connection at the bottom right)

However, the mounting position with air flow from the right to the left in the direction of aspiration (compressed-air connection at the top left) is not permissible!

7.1.2 Installation of the Automatic Purging Units Series F-BO-AFE70-2

Remove the two M3 screws from the cover and lift the cover of the Purging unit.

Position the Purging unit at a suitable place on the wall, so that later it can be easily connected to the sensor pipe, the evaluation unit of the smoke aspiration system and the compressed air. While

doing so, note the permissible mounting positions of the Purging unit and the mounting examples shown above in Fig. 6.

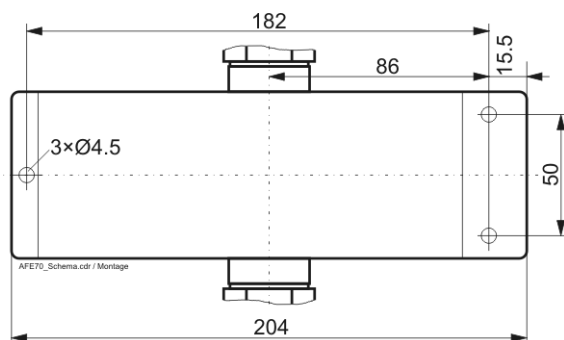

Fig. 7: Schematic illustration of the mounting holes of the Automatic Purging Units Series F-BO-AFE70-2

Mark the three mounting points of the bottom plate of the Purging unit, as shown above in Fig. 7, on the wall and drill the mounting holes with a diameter of 6mm. Insert the plugs into the holes and use the mounting screws to screw the bottom plate with the assembled valve block to the wall.



Since the installation of a smoke aspiration system (laying the sensor pipes, making the electrical connections, etc.) can extend over a longer period, it is recommended that the cover be reinstalled immediately after completion of the work on the Purging unit, and that the free openings of the 25mm push-in fittings as well as of the compressed-air connection be kept closed until the pipe network is connected, in order to protect the Purging unit.

7.2 Connection to the sensor pipe and to the evaluation unit of the smoke aspiration system

For safety reasons and in order to allow easy connection, the Automatic Purging Units Series F-BO-AFE70-2 are delivered with two 25mm push-in fittings which have to be installed as described in Chapter 5.1.



Using other fittings or other components instead of the supplied 25mm push-in fittings can lead to severe injuries or damage and therefore has to be refrained from!

The connection between the Purging unit and the sensor pipe must be airtight and pressure-resistant, the connection between the Purging unit and the evaluation unit of the smoke aspiration system must be airtight, but it does not have to be pressure-resistant. Therefore make sure you choose the suitable material.

The 25mm push-in fittings are designed to allow insertion of pipes with an outside diameter of 25mm and to let claws hinder the pipes from gliding out. The pipe is hermetically enclosed by a gasket.

For this purpose, the pipe that is to be inserted must be cut at a right angle and the cut surface must be perfectly deburred on the inside and on the outside. Furthermore, the outer surface has to be provided with a 30° chamfered edge, so as not to damage the gasket when inserting the pipe (see Figure 8).

It is recommended that the pipes from the Purging unit to the sensor pipe as well as to the smoke aspiration system should be constructed in such a way that, even after completed installation, the pipes can still be pulled out from the 25mm push-in fittings by approximately 45mm in order to make commissioning and maintenance easier.

The pipe is connected by carefully inserting the pipe, which has been prepared as described above, into the 25mm push-in fitting as far as it will go, the insertion depth is approximately 39mm. After completing these activities, check the correct fit of the pipe.

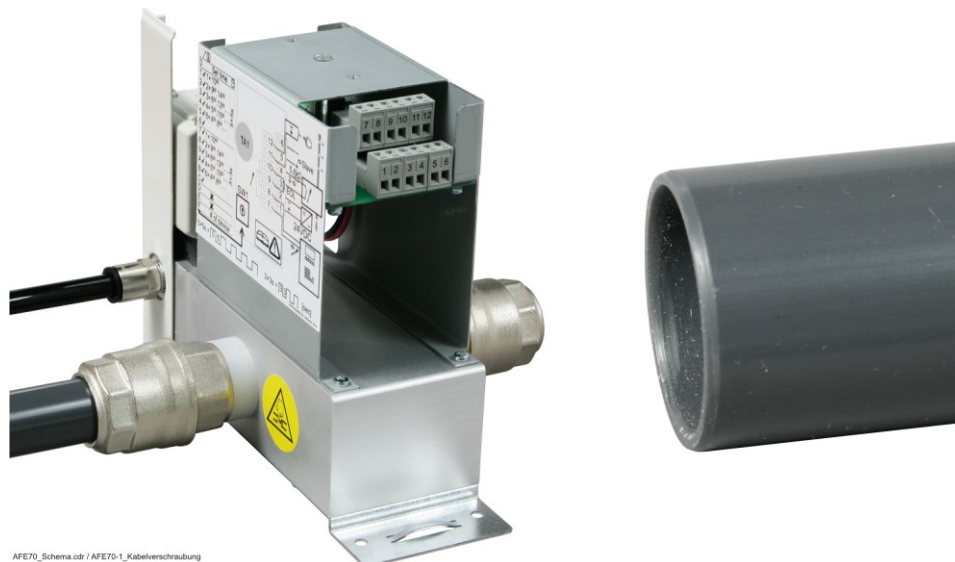

AFE70_Schema.odt / AFE70-1_Kabelverschraubung

Fig. 8: F-BO-AFE70-1 with push-in fittings and a pipe connected on one side, as well as a close-up of the pipe that has been prepared for the connection.



The sensor pipe network that is connected to the Automatic Purging Unit Series F-BO-AFE70-2, including all components installed in the pipe, such as filters, must be designed such that it withstands the static overpressure of the connected compressed-air supply with sufficient safety. Although usually this pressure is never reached during normal operation, this pressure can be reached in case of severe clogging of the piping. Therefore you absolutely have to contact the suppliers of the components and make sure that the components meet the requirements.



If the sensor piping and the components connected to it have not been laid professionally or if components are used which do not withstand the maximum pressure that is available, severe injuries or damage can occur!



It is recommended that, if possible, the smoke aspiration system should only be installed in the course of commissioning the Purging unit, because the pneumatic connection between the Purging unit and the smoke aspiration system has to be interrupted when commissioning starts.

7.2.1 Loosening the pipe connection

The Purging unit's connection to a 25mm pipe can also be loosened again by unscrewing the 25mm push-in fittings.



Make absolutely sure that, before starting this activity, both the supply line of the compressed air as well as the supply voltage are reliably turned off or disconnected and that they can not be turned on or connected again by mistake.

To unscrew the 25mm push-in fitting you need a suitable wrench for applying a counteracting force on the hexagon surface of the push-in fitting (wrench size 32mm), as well as a suitable adjustable wrench (or, if necessary, a suitable pair of pliers) for unscrewing the push-in fitting via the octagon surface (wrench size 35mm). It is not necessary to disassemble the push-in fitting, it only has to be unscrewed as far as necessary to easily pull out the pipe by hand. When unscrewing the connection, also make sure that the push-in fitting is not screwed off from the valve body by mistake.

Before the 25mm push-in fitting can be used again after pulling out the pipe, it must be screwed together again (3Nm torque) and checked for flawless condition of all components.



After finishing the work, make sure that the fit of the push-in fittings is correct and safe.

7.2.2 Use of filters

If it must be expected that the air that is drawn in by the smoke aspiration system will be particularly dirty, it is recommended that an air filter should be installed between the sensor pipe network and the Purging unit. Without appropriate prefiltering of the intake air, the accumulation of dust inside the housing of the Purging unit can cause increased abrasion or even result in the valve piston getting stuck.

In the event of a fault in the purification of the compressed air, solid or liquid particles in the compressed air which are aspirated again by the smoke aspiration system after the Purging process has been carried out, can cause false alarms or result in the rapid contamination of the smoke aspiration detector. As a precaution it is therefore recommended that a prefilter should be used between the Purging unit and the evaluation unit of the smoke aspiration system.



Many types of smoke aspiration systems already have prefilters built into their evaluation unit, as a result a separate prefilter between Purging unit and evaluation unit is not needed.



In any case, filters must comply with the system approval of the smoke aspiration system used and must be taken into consideration when calculating the pipe in accordance with EN 54-20. Pay attention to the project planning instructions of the manufacturer of the smoke aspiration system.

7.2.3 Use of check valves

It is recommended that a check valve should be mounted at the end of every branch of the sensor pipe network. Mounting a check valve ensures that the dirt particles will be blown out of the pipe in the best possible way. In addition, the check valve also serves to limit the pressure in the piping, thereby relieving the aspiration holes during the Purging process. Ideally, the opening overpressure of the check valve should be around 25kPa (0.25bar).



The cleaning of the aspiration holes is also ensured without a check valve, but it is not ensured that the dirt particles will be blown off along the whole length of the pipe in the best possible way.

7.2.4 Connection diagram for a double pipe system

The following figure shows the schematic connection of the components needed for blowing off two separate sensor pipe networks of the evaluation unit of a smoke aspiration system.

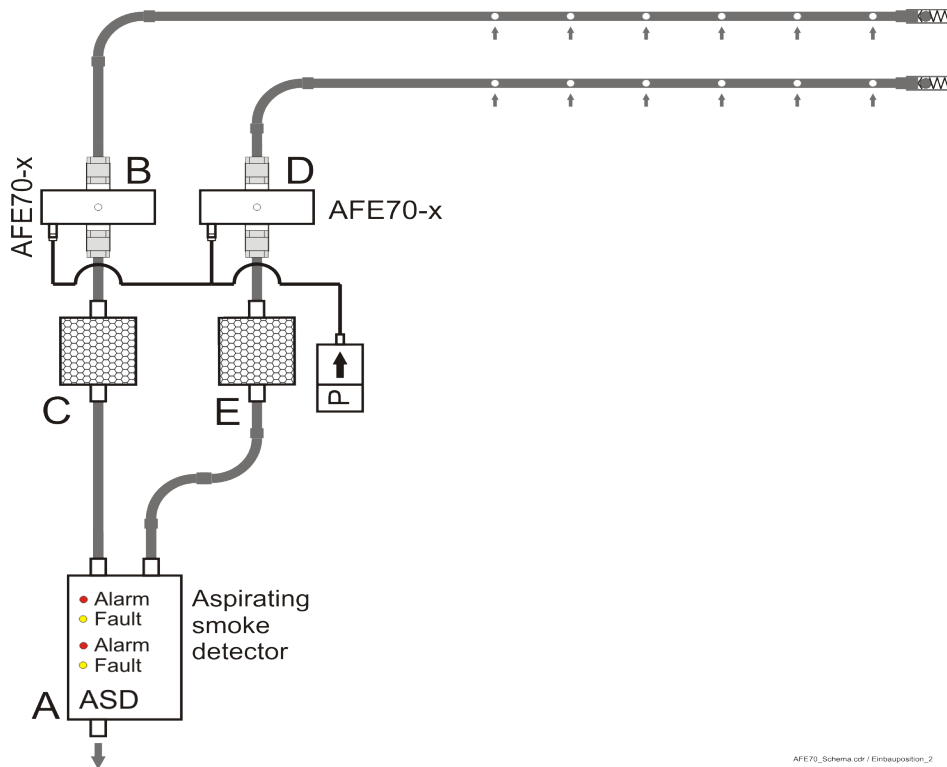

Fig. 9: Smoke aspiration system with two separate pipe systems. As a supplement to Fig. 2 (page 10), electrical connection cables are not shown here in order to provide a clearer overview.

A ... Smoke aspiration system with two separate pipe systems

B ... F-BO-AFE70-2 for the first pipe network

C ... Filter (pressure-resistant version required!) before the Purging unit, pipe network 1

D ... F-BO-AFE70-2 for the second pipe network

E ... Filter (pressure-resistant version required!) before the Purging unit, pipe network 2

If the used evaluation unit of the smoke aspiration system has separate fault outputs for each individual pipe network, the Purging units can be actuated individually. As a result, the pipes can also be blown off independently of each other in the event of a fault.

If the used evaluation unit of the smoke aspiration system does not have separate fault outputs for each individual pipe network, but has only one common fault output for all pipe networks, the Purging units must be connected and operated in the master-slave mode. In this case, the pipes will always be blown off together.

7.2.5 Connection diagram for far-flung sensor pipe networks with master-slave mode of the Purging units

The following figure shows the schematic connection of the components needed for blowing off far-flung sensor pipe networks, using the example of a double-U pipe network. The two Purging units are operating in the master-slave mode, therefore both U pipe segments are blown off together.

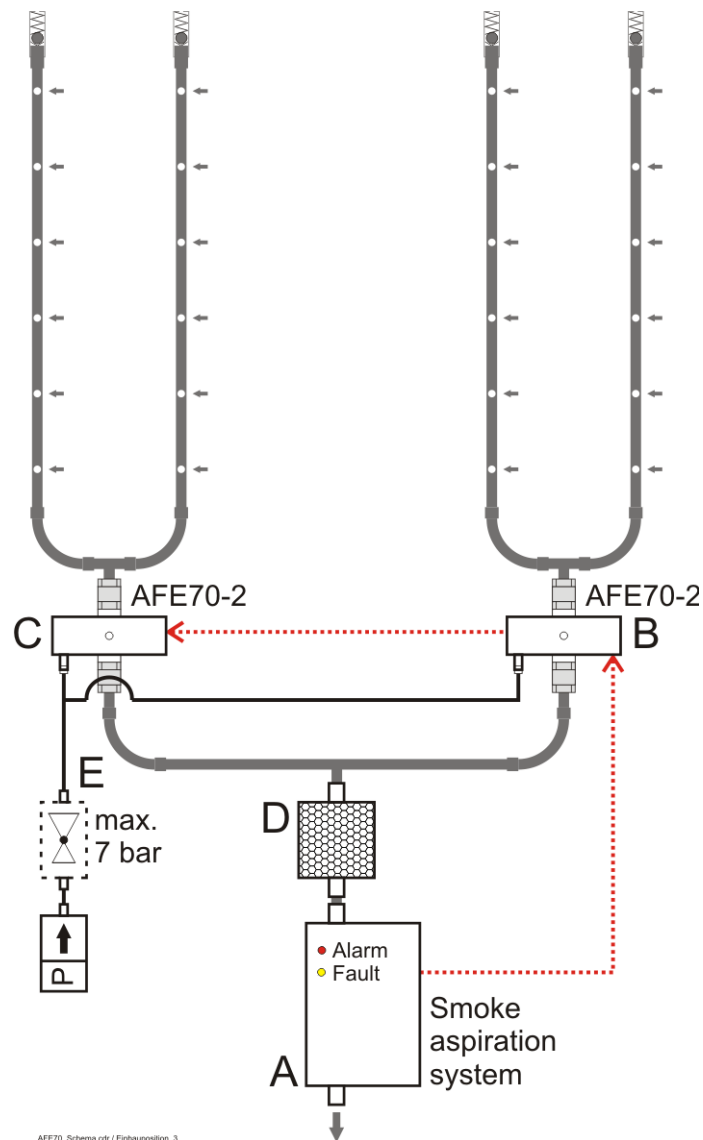

Fig. 10: Smoke aspiration system with one pipe network and two F-BO-AFE70-2-2's in master-slave arrangement. In the example, two F-BO-AFE70-2-2's are needed because of the total aperture area of the aspiration holes.

As a supplement to Fig. 2 (page 10), the electrical connection cables are not shown here in order to provide a clearer overview; however, the logical sequence of the Purging process has been drawn in with red dotted arrows.

A ... Smoke aspiration system with pipe networks in double-U design

B ... F-BO-AFE70-2 (master) for the first U pipe network

C ... F-BO-AFE70-2 (slave) for the second U pipe network

D ... Filter for the entire pipe network. Since most smoke aspiration systems only permit one external filter per pipe network, in the example above the filter must be located behind the two Purging units.

E ... A pressure regulator must be used if the used compressed-air supply can exceed the permissible pressure



Which one of the two Purging units works as master unit and which one as slave unit is only determined by the order in which they are cabled. The unit which receives the fault message from the smoke aspiration system is the master unit, the unit that is actuated by the master unit is the slave unit.

7.3 Connection of the compressed air

The Automatic Purging Units Series F-BO-AFE70-2 are provided with commercial push-in fittings for easily connecting the compressed air via a hose with an outer diameter of 10mm.



The push-in fitting of the Automatic Purging Unit F-BO-AFE70-2-2 may only be connected and disconnected by applying a counteracting force on the pipe elbow on the input of the valve in order to avoid excessive strain. Connection and disconnection without applying an adequate counteracting force can cause damage to the solenoid valve, the cover of the Purging unit and the push-in fitting.



It is recommended that a shut-off device for the compressed air should be installed before the compressed-air connection of the Purging unit; this makes installation, commissioning and any maintenance jobs easier.



Only turn on the compressed-air supply after finishing all mounting, installation, connection and parameterisation work in the course of commissioning, as described starting on page 38 in Chapter 9: „Commissioning and function test“. Turning on the compressed-air supply at an earlier time can result in severe damage or injuries, depending on the condition of the system and the environment.



The compressed-air supply must be engineered in such a way that the maximum permissible positive operating pressure of the Automatic Purging Units Series F-BO-AFE70-2 will not be exceeded, see from page 41 onwards in Chapter 11: „Specifications“.

If the used compressed-air supply can exceed the permissible pressure, a pressure regulator must be used. This pressure regulator must be constructed in such a way that it does not limit the air flow rate in an inadmissible way. The maximum permissible positive operating pressure as well as the recommended air flow rate for the Purging unit that you are using can be found from page 41 onwards in Chapter 11: „Specifications“.

Furthermore, the compressed-air supply must be engineered such that the compressor and the air vessel as well as the supply line up to the Automatic Purging Unit Series F-BO-AFE70-2 are sufficiently dimensioned, so that during the Purging process the pressure that is available at the input of the Purging unit does not decrease to an insufficient value, in which case the required air flow rate would no longer be ensured for the duration of the Purging process.



The compressed air must always be clean and free from oil and water or other contamination. If compressed air is used which is not sufficiently purified, these contaminations can result in malfunctions of the Purging unit or of the smoke aspiration system. For example, the valve piston system of the Purging unit can ice up or the measuring device of the smoke aspiration system can become oily, and therefore can become useless or can even be destroyed. This can also lead to false alarms or increased contamination of the smoke aspiration detector as a result of particles in the compressed air, which are again drawn in by the evaluation unit of the smoke aspiration system after a Purging process.

8 Connection and parameterisation

In this chapter the basic connection of the Automatic Purging Unit Series F-BO-AFE70-2 to a smoke aspiration system is described.



Beware of static charges! The electronic components used in the Automatic Purging Units Series F-BO-AFE70-2 can be destroyed by static charges when the device is open. Before and during the work being performed on printed circuit boards, static charges from your body must be reliably discharged by touching an earthed piece of metal.

8.1 General instructions

You have to choose the wire gauge of the connection cables to the external components, taking into consideration the current consumption of the connected equipment as well as the length of the cables. When dimensioning the cables, do consider the voltage drop which, in the event of actuation, is briefly caused by the solenoid valve current (see from page 41 onwards in Chapter 11: „Specifications“). To ensure adequate mechanical strength, the wire diameter should not drop below 0.6mm for the connection of external components.

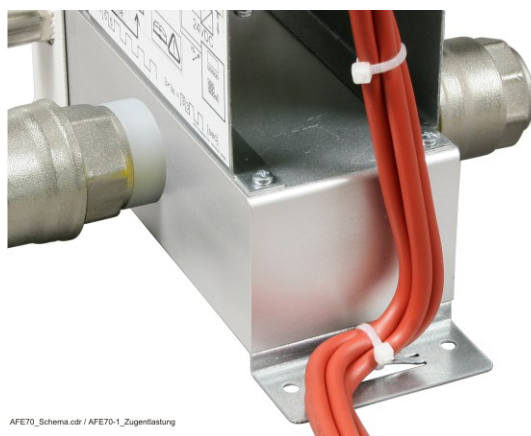

Fig. 11: Cables fastened to the bottom plate of the F-BO-AFE70-1

In the Purging unit, the laid cables must be pull-relieved. On the bottom plate there is a deep drawn loop that is intended for pull-relieving the inserted cables (see Fig. 11 above) by fastening them to this loop – using a cable tie (included in the packet of assembly material that is enclosed with the Purging unit).

If shielded cables are used for the installation, the shielding wires must be connected to earth on one side. The shielding wires of an interrupted wiring path (e.g., in an intermediate distributor) must be safely connected with each other.



The Automatic Purging Unit Series F-BO-AFE70-2 is protected against electrical interference using elaborate means. As a result, under normal environmental conditions, shielded cables are not needed for safe operation.



Observe the regional installation regulations for fire alarm systems as well as the relevant regulations for electrical installations!



Only turn on the compressed-air supply after finishing all mounting, installation, connection and parameterisation work in the course of commissioning, as described starting on page 38 in Chapter 9: „Commissioning and function test“. Turning on the compressed-air supply at an earlier time can result in severe damage or injuries, depending on the condition of the system and the environment.

In order to provide a clearer overview, the components of the EMC protection circuits of the inputs and outputs that are provided on the control board are not shown in the connection diagrams.

8.2 Power supply

The Purging unit can be powered by a separate power supply unit, or by the power supply device of the smoke aspiration system or of the fire detection control panel.



Most European installation regulations stipulate that smoke aspiration systems must be powered by a power unit which has been tested according to EN 54-4. Usually this requirement does not apply to the Purging unit. However, in case of appropriate connection, the F-BO-AFE70-2 will transmit the failure of the supply voltage to the fire detection control panel as fault.

In order to avoid undefined potential situations, the inputs and outputs for the control lines between the Purging unit and the evaluation unit of the smoke aspiration system are potential-free within the unit.



If several Purging units, each with its own independent power supply device, are operated with a common timer for synchronising the time or with a common push-button „Manual activation“ or something similar, the supply voltage minus terminals of the Purging units (terminal 2) must be connected to each other.

8.3 Location of the display and operating elements and terminals on the control board of the Automatic Purging Units Series F-BO-AFE70-2

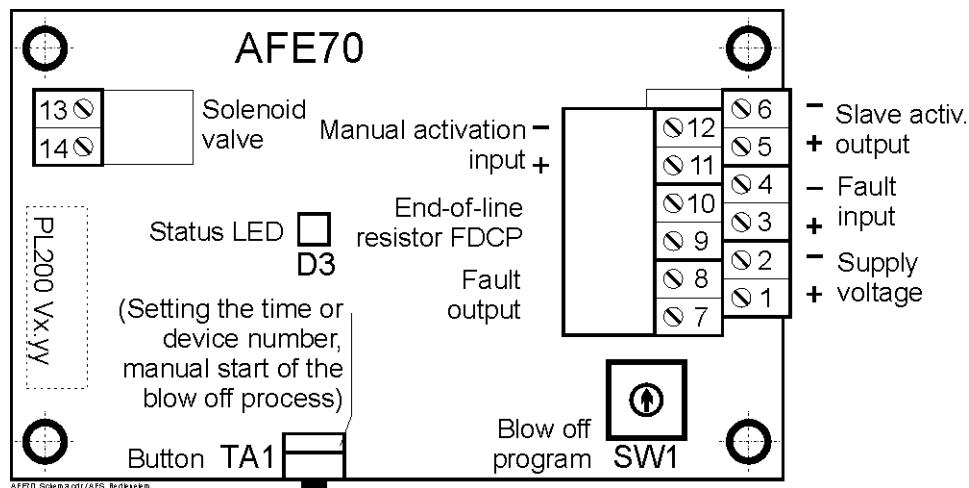

Fig. 12: Location of the display and operating elements and terminals on the control board AFS70-1 of the Automatic Purging Unit Series F-BO-AFE70-2. The field with the dotted border is a label on which the version of the used firmware „PL200 Vx.yy“ has been printed.

8.4 Connection of and interaction between Purging unit, smoke aspiration system and fire detection control panel

Perform the connection in accordance with Figures 13 or 14 below. The connections that are needed for the respective function are represented by solid lines, the optional connections are represented by dashed lines.



All contacts in Figures 13 and 14 are shown in the de-energised condition of the devices, which means

- the fault contacts of the F-BO-AFE70-2 and of the smoke aspiration system are in the „fault“ condition.
- the alarm contact of the smoke aspiration system is in the „no alarm“ condition.

The alarm contact of the smoke aspiration system is connected to the fire detection control panel like a standard fire detector, by means of a monitored line (e.g., via a conventional line or a loop input module). The alarm resistor RAL allows the fire detection control panel to distinguish between short circuit on the line and alarm of the smoke aspiration system, the end-of-line resistor REOL FDCP allows the detection of a wire breakage between the Purging unit and the fire detection control panel. For the required resistance values of the resistors RAL and REOL FDCP, please refer to the connection documentation of your fire detection control panel. The end-of-line resistor REOL

AFE (5.6kOhm) is needed for the detection of the breakage of the line between the smoke aspiration system and the Purging unit.

In the normal operation of the Purging unit, the fault message of the smoke aspiration system will be evaluated like a breakage of the line between the smoke aspiration system and the Purging unit and will be processed as follows: the Purging unit will delay the transmission of the fault message to the fire detection control panel and will start an automatic Purging process according to your parameter setup. After completion of the Purging process, an observation period of 60 seconds will follow; if the fault or the wire breakage still exists after that, the Purging unit will disconnect the end-of-line resistor R_{EOL} FDCP, thereby transmitting the fault to the fire detection control panel.

A short circuit on the line between the smoke aspiration system and the Purging unit will be immediately detected and indicated by the status LED. If the short circuit exists for less than 50 seconds, the fault will be reset automatically. If the short circuit exists for a period of between 50 and 70 seconds, this will be evaluated by the Purging unit as command for the synchronisation of the time. If the short circuit exists for more than 70 seconds, this will be transmitted to the fire detection control panel as fault by disconnecting the end-of-line resistor R_{EOL} FDCP.

8.4.1 Standard connection

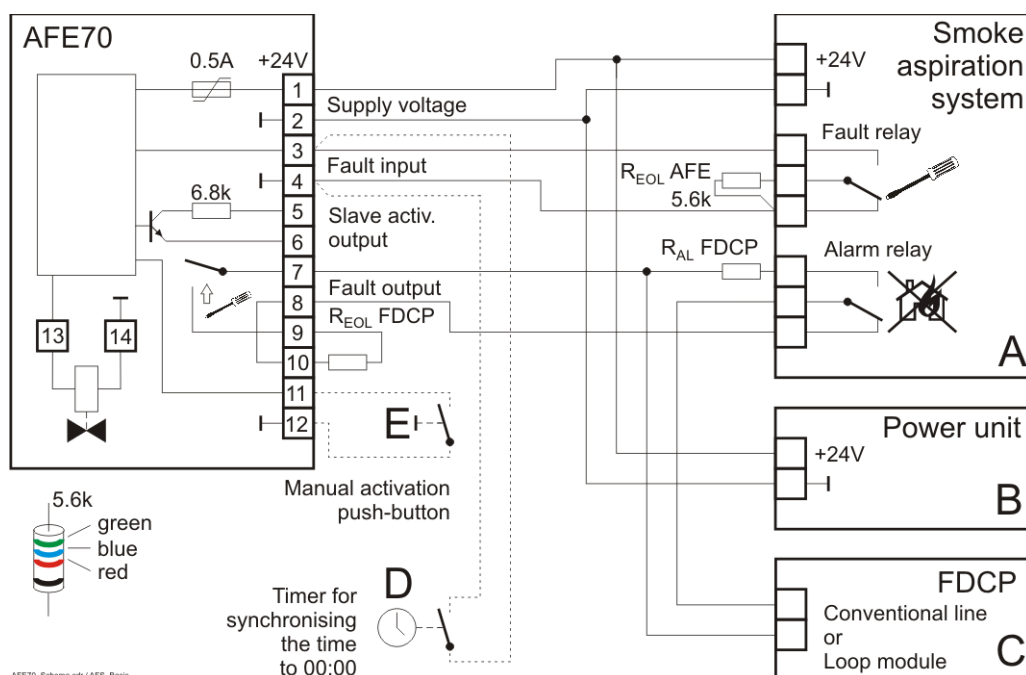

Fig. 13: Standard connection of the Automatic Purging Unit Series F-BO-AFE70-2 to the FDCP and to a smoke aspiration system, via a monitored line. All components are only shown as schematic diagram, with the exception of the Purging unit.

- A ... Smoke aspiration system (in order to provide a clearer overview, only the connections that are absolutely necessary for the Purging unit are shown).
- B ... Power unit (observe the country-specific regulations for the power supply of smoke aspiration systems and special detectors).
- C ... Fire detection control panel (observe the connection conditions for the fire detection control panel used).
- D ... Optional timer for synchronising the time on the Purging unit
- E ... Push-button for the manual activation of the Purging process

8.4.1.1 Push-button „Manual activation“

If a push-button (or another switching device) that is connected to the „Manual activation“ input is activated, compressed air will be blown into the pipe network – regardless of the set Purging program – for as long as the push-button is being pressed, but for reasons of safety the duration is limited to 2 minutes. A new manual Purging process can only be started again via the input if the push-button is pressed again.

This input can also be used for controlling the Purging processes by means of external timers.



The input „Manual activation“ is always evaluated, which means that the actuation of the input will also be evaluated and processed while an automatic Purging cycle is carried out.

8.4.1.2 Output „Slave activation“

This dry output is used if one or more „slave“ unit(s) F-BO-AFE70-2 is/are to be actuated by the „master“ unit F-BO-AFE70-2. The „slave“ units start virtually at the same time as the master unit. If a device number has been set on the master unit, it will be evaluated, a device number that has been set on a slave unit will have no effect.

8.4.1.3 Synchronisation of the internal clock of the F-BO-AFE70-2

By means of an impulse from an external timer, with a duration of approx. 1 minute, the internal clock of the F-BO-AFE70-2 can be set to 00:00 hours (i.e., always at midnight). For more details see from page 35 onwards in Chapter 8.5.2: „Internal clock“.

8.4.2 Connection of Purging units in the master-slave mode

If the air delivery volume required in a far-flung pipe network makes it necessary to use more than one Purging unit in order to safely clean the pipe network, the Purging units can be operated in the master-slave mode.

Any number of Automatic Purging Units Series F-BO-AFE70-2 can be operated in the master-slave mode. Since all slave units follow the Purging processes of their master unit virtually synchronously, you have to take into account the increased air delivery volume needed for this.



Pay attention to the project planning instructions given from page 15 onwards in Chapter 4: „Pneumatic components – dimensioning“ and from page 41 onwards in Chapter 11: „Specifications“.

All slave units must be operated with Purging program 6. Setting device numbers on slave units will not affect the sequence in time.

Further explanations about the general connection as well as the inputs and outputs can be found in the above-mentioned parts of Chapter 8.4: „Connection of and interaction between Purging unit, smoke aspiration system and fire detection control panel“.

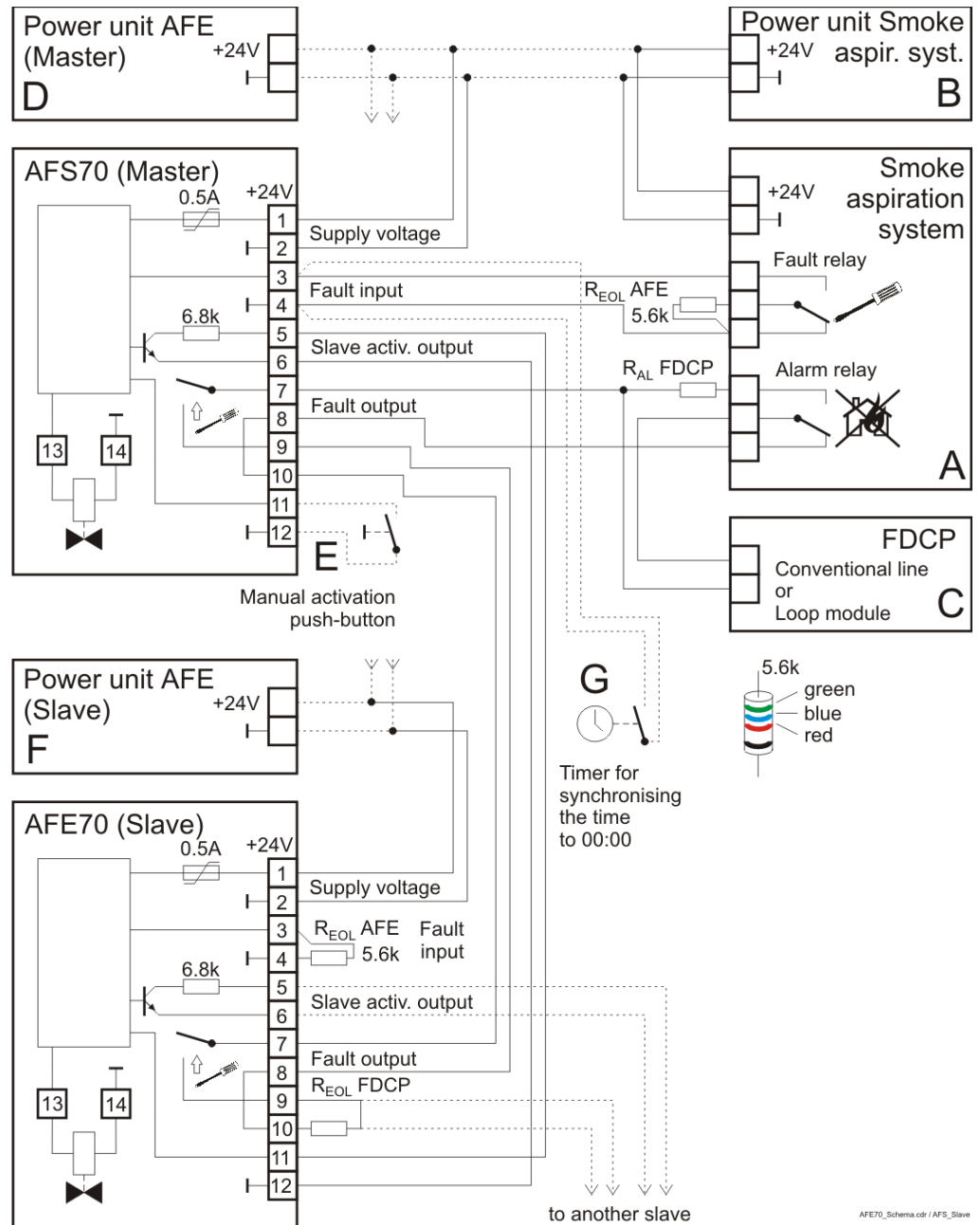

Fig. 14: Connection of two Automatic Purging Units Series F-BO-AFE70-2 in the master-slave mode. The upper Purging unit, which has the connection to the fault output of the smoke aspiration system, serves as master unit. This F-BO-AFE70-2 uses its „Slave activ.“ output to control the slave unit, which is actuated via the „Manual activation“ input. If additional slave units are to be actuated, it is recommended that each additional slave unit should be actuated via the „Slave activ.“ output of the respective preceding slave unit. In order to prevent the slave units from carrying out autonomous Purging processes, the slave units must be set to Purging program „6“ and the end-of-line resistor $R_{EOL} AFE$ must be connected to the fault input. The fault outputs of the master unit and of all slave units must be connected in series, the end-of-line resistor $R_{EOL} FDCP$ must be installed in the last slave unit.

A... Smoke aspiration system (in order to provide a clearer overview, only the connections that are absolutely necessary for the Purging unit are shown).

B ... Power unit for the smoke aspiration system (observe the country-specific regulations regarding the power supply of smoke aspiration systems and special detectors).

C ... Fire detection control panel (observe the connection conditions for the fire detection control panel used).

D ... Power unit for the master Purging unit

E ... Push-button for the manual activation of the Purging units
The activation of this input will result in the activation of the master unit and of the connected slave units.

F ... Power unit for the slave Purging unit

G ... Optional timer for synchronising the time on the Purging unit



The smoke aspiration system, the master unit as well as all slave units can be powered by different power supplies or by the same power supply.



If several Purging units, each with its own independent power supply device, are operated with a common timer for synchronising the time or with a common push-button „Manual activation“ or something similar, the supply voltage minus terminals of the Purging units (terminal 2) must be connected to each other.

8.5 Parameterisation of the Purging unit

8.5.1 Setting the Purging program

The desired Purging program is set by means of the rotary switch „Purging program“ SW1 (see on page 35 in Table 8 and on page 37 in Fig. 17).



In switch positions „1“ through „C“ of rotary switch SW1, the selected Purging program will be carried out as soon as the smoke aspiration system reports a „fault“ (e.g., the air flow through the sensor piping is impeded by contamination), independent of the time.

In the Automatic Purging Unit F-BO-AFE70-2, two Purging processes with different duration and number of impulses can be selected:

- ◆ the „short“ Purging process carries out 3 impulses with a duration of 3 seconds each and with 2 pauses of 3 seconds in between, i.e., with a total duration of approx. 15 seconds, and is intended for normal contamination,
- ◆ the „long“ Purging process carries out 5 impulses with a duration of 5 seconds each and with 4 pauses of 5 seconds in between, i.e., with a total duration of approx. 45 seconds, and is intended for persistent contamination.



Please note that more compressed air is needed for the long Purging process.

SW1	Purging program
0	Setting the time – manual activation not possible
1	Once a day at 10:00 and in case of a fault, always with long Purging process
2	Twice a day at 09:00 and 14:00 and in case of a fault, always with long Purging process
3	Three times a day at 06:00, 12:00 and 18:00 and in case of a fault, always with long Purging process
4	Four times a day at 5:00, 10:00, 15:00 and 20:00 and in case of a fault, always with long Purging process
5	Six times a day at 4:00, 8:00, 12:00, 16:00, 20:00 and 00:00 and in case of a fault, always with long Purging process
6	Long Purging process in the event of a fault of the evaluation unit of the smoke aspiration system. This program is also to be used if the Purging processes are only started by a push-button, or if the Purging unit operates as „slave“.
7	Once a day at 10:00 and in case of a fault, always with short Purging process
8	Twice a day at 09:00 and 14:00 and in case of a fault, always with short Purging process
9	Three times a day at 06:00, 12:00 and 18:00 and in case of a fault, always with short Purging process
A	Four times a day at 5:00, 10:00, 15:00 and 20:00 and in case of a fault, always with short Purging process
B	Six times a day at 4:00, 8:00, 12:00, 16:00, 20:00 and 00:00 and in case of a fault, always with short Purging process
C	Short Purging process in the event of a fault
D	No Purging program; a fault will be transmitted without delay, manual activation is not possible

E	No Purging program; a fault will be transmitted without delay, manual activation is not possible
F	Setting the device number - manual activation not possible

Table 8: Setting the program with the rotary switch „Purging program“ SW1



If no Purging program has been set (i.e., the rotary switch „Purging program“ SW1 is in one of the positions „0“, „D“, „E“ or „F“), an activation of the fault input will immediately result in an activation of the fault output.



All slave units must be operated with Purging program 6.

8.5.2 Internal clock

Every time the supply voltage is applied, the time is automatically set to 10:00.



If a Purging program which carries out a periodical Purging process at 10:00 has been set, the Purging unit will start the first Purging process immediately after the supply voltage has been switched on.



The internal clock can only be set to a full hour. If very exact Purging times must be kept to, you have to use a correspondingly accurate external timer for the control of the Purging processes.



While the time is being displayed or set, the light colour of the status LED is red.

8.5.2.1 Displaying and manually setting the time

Turn the rotary switch „Purging program“ SW1 to the „0“ position. Immediately afterwards the status LED will indicate the hours value of the time as one (one-digit hours value) or two (two-digit hours value) series of red blink pulses. A series of ten blink pulses stands for the digit „0“.

- ◆ If the status LED is blinking, for example, 8 times, the set time is between 08:00 and 08:59.
- ◆ If the status LED is blinking, for example, once, and after a pause of 2 seconds, a further 5 times, the set time is between 15:00 and 15:59.
- ◆ If the status LED is blinking, for example, twice, and after a pause of 2 seconds, a further 10 times, the set time is between 20:00 and 20:59.

After the indication of the time, you can either set the time anew or terminate the process by exiting position „0“ of the rotary switch „Purging program“ SW1. Since the clock can only be set to a full hour, it is recommended that it should always be set at the full hour.

You start the entry by pressing TA1 for at least 2 seconds. When the status LED lights up, release TA1 and start entering the hours within 4 seconds: if the hours value has two digits (10-24), start with the tens digit, if the hours value has one digit (1-9), only enter the ones digit.

- ◆ Press the button once or several times – according to the number you want to enter – with intervals of less than 2 seconds, every press of the button will be confirmed by the status LED which will light up briefly. The digit „0“ is entered by pressing the button ten times. 2 seconds after the last press of the button, the completion of the entry will be confirmed by the status LED which will light up briefly.
- ◆ If the hours value has two digits, you can now start the entry of the ones digit within 4 seconds, in the same way as described above.
- ◆ 4 seconds after the last confirmation of an entry, the entered hours value of the time will be displayed in the same way as already described in this section.

After completion of the entry and indication of the entered value, the status LED will flash in green because no Purging program has been set.



Since the Purging unit has no built-in back-up battery for the clock, it will immediately lose the current time in the event of a power failure. If the supply voltage is applied again, it will start again with 10:00 and will have to be set anew.



If you have made a mistake while entering the time, you can repeat the entry as often as you like.



A switch between summer time and winter time is not provided for, if it is required, you either have to use an external timer for controlling the Purging processes, or you have to synchronise the time automatically.

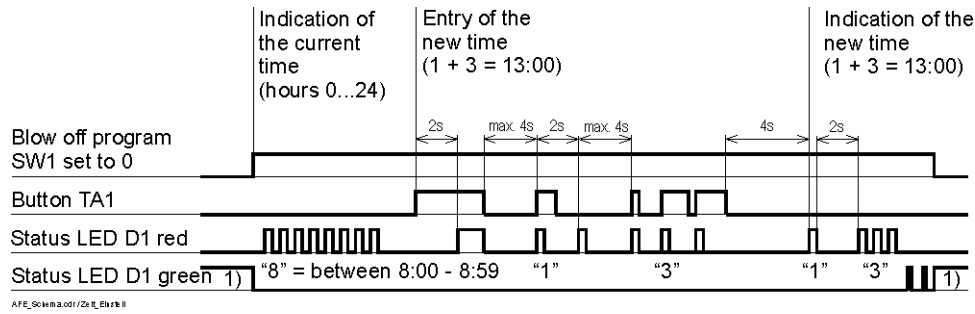

1) The status LED illuminates green as long as a valid Purging program is set.

Fig. 15: Parameterisation of the internal time of the Purging unit

8.5.2.2 Automatically synchronising the time

In addition to manually setting the time, the time of the Purging unit can also be set to 00:00 hours by means of an external timer. This is done by short-circuiting the line to the fault input (terminals 3 and 4 of the Purging unit) for a duration of between 50 and 70 seconds; by removing the short circuit the internal clock will be set to 00:00.



You can realise this, for example, by means of a timer which is programmed in such a way that its output closes daily at 23:59 and opens again at 00:00 hours.



If the short circuit exists for more than 70 seconds, this will be evaluated as fault! If the short circuit on the fault input exists for less than 50 seconds, this will be indicated by the status LED, but apart from that it will not be evaluated.

8.5.3 Setting and displaying the device number

If several Automatic Purging Units Series F-BO-AFE70-2 are used in the automatic mode with Purging program, and if they are connected to a common compressed-air system, a staggered operation helps to avoid overstressing of the compressed-air supply.

For this purpose, the Purging units can be programmed with a device number between 0 and 32. The factory setting of the devices is no. 0. By increasing the device number by 1, the Purging process of the respective Purging unit is delayed by 2 minutes, so that only one Purging unit consumes compressed air at any one time. The maximum possible time delay is $32 \times 2 = 64$ minutes.



At the set start time, the Purging unit with device number 0 will start, 2 minutes later the device no. 1 will start, another 2 minutes later the device no. 2 will start, etc. As a prerequisite, of course the time of all Purging units involved must have been set to the same time.

In order to program the device number you have to turn the rotary switch „Purging program“ SW1 to position „F“. Apart from that, the device number is displayed and set in the same way as the time, as explained from page 35 onwards in Chapter 8.5.2.1: „Displaying and manually setting the time“.



The device number is stored in the nonvolatile memory of the Purging unit. Therefore the device number will remain stored indefinitely even if the Purging unit is not being powered.

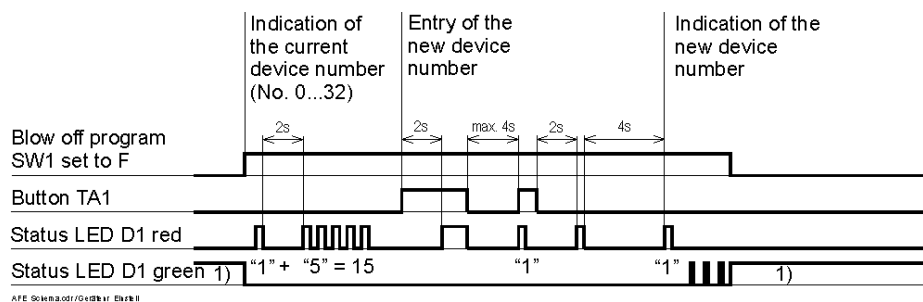

1) The status LED D1 illuminates green as long as a valid Purging program is set.

Fig. 16: Parameterisation of the device number of the Purging unit

8.6 Label showing the parameterisation options and connection possibilities

On the Purging unit, on the side of the pipe connection to the smoke aspiration system, a label showing the possible Purging programs as well as the terminals is visible after removing the cover of the Purging unit. This label serves as support for the connection and parameterisation carried out by the experienced expert installer and under no circumstances does it replace this User Manual.

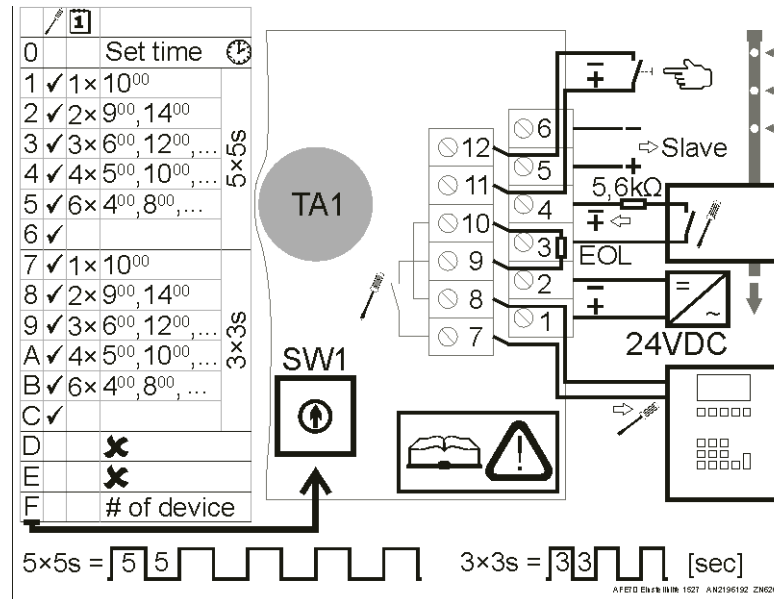

Fig. 17: Label showing the possible Purging programs, the location of the display and operating elements and the location of the terminals.

9 Commissioning and function test

This chapter is devoted mainly to providing general information and showing a recommended sequence aimed at facilitating rapid and successful commissioning of an Automatic Purging Unit Series F-BO-AFE70-2.



The major prerequisites for successful commissioning are the expert installation and the correct connection of the Purging unit.

Before and during commissioning, go through the following checklist point by point in order to make the commissioning smooth and safe:



Pay attention to the danger notices given on page 3.



In order to exclude an undesired activation of the Purging unit completely, you have to reliably turn off or interrupt the compressed-air supply to the Purging unit prior to commissioning and make sure that it can not be turned on or connected by mistake.



Before carrying out the first Purging processes, make sure that all connections in the system are flawless and the glue of the joints has sufficiently hardened. Make absolutely sure that both the supply line of the compressed air as well as the supply voltage are reliably turned off or disconnected and that they can not be turned on or connected again by mistake.



Make sure that, during the first Purging processes, no persons are present in the area of the pipe network and especially in the area of the Purging openings and the opening of the check valve; solid bodies and liquids that are driven by the compressed air can escape with high velocity and can cause injuries!



Take care that fingers, other parts of the body, and objects never get into the open pipe connection opening. During the Purging process, the valve that is integrated into the Automatic Purging Unit Series F-BO-AFE70-2 is closed with high velocity and great force. As a result, parts of the body or objects, which are in the valve body, can be seriously injured or even severed or destroyed respectively! In addition, the Purging unit can be severely damaged or destroyed as a result.

Integration into the pipe network:

- ◆ Has the Purging unit been integrated into the pipe network at the correct position and has the glue of the joints hardened completely?
- ◆ Have the 25mm push-in fittings been connected to the valve body and are these connections firm and airtight?

Opening the pipe connection to the smoke aspiration system:

- ◆ Open the pipe connection between the evaluation unit of the smoke aspiration system and the Purging unit and make sure that no contamination can get into the aspiration opening of the smoke aspiration system.

Cabling:

- ◆ Is the cabling both to the fire detection control panel and to the evaluation unit of the smoke aspiration system correct and complete?
- ◆ Make sure that no fault of the smoke aspiration system exists on the fault input of the Purging unit. In order to make this absolutely sure, a 5.6kOhm resistor, instead of the smoke aspiration system, can be temporarily connected to the fault input for the time of commissioning.

Connection of the supply voltage:

- ◆ Make sure that the compressed-air supply to the Purging unit has been turned off.
- ◆ Set the rotary switch „Purging program“ SW1 to „0“, which means that no Purging program is set.
- ◆ Connect the supply voltage – the „status LED“ of the Purging unit must be flashing green.
- ◆ Set the program switch SW1 to position 6 (which means that only faults of the smoke aspiration system will be evaluated, but Purging processes according to the internal clock will not be carried out).
- ◆ Does the „status LED“ of the Purging unit illuminate green?

Connection of the compressed-air supply:

- ◆ Make sure that the „status LED“ of the Purging unit illuminates green and no fault can exist on the fault input of the Purging unit.
- ◆ Make sure that the compressed air and particles flowing out from the aspiration holes and the check valve can not cause any damage.
- ◆ Turn on the compressed-air supply to the Purging unit **slowly**, so that the pressure can build up slowly.

Carrying out manual cleaning processes:

- ◆ Carry out some manual Purging processes by electrically connecting the terminals 11 and 12 (input „Manual activation“) briefly in order to gently remove possible contaminations in the pipe network. Start with very short impulses (with a maximum duration of 1 second) and slowly increase the time from impulse to impulse until the piping is completely filled with pressure and a continuous Purging process is achieved.
- ◆ Turn off the compressed-air supply to the Purging unit.
- ◆ Carry out another manual Purging process in order to relieve the residual pressure in the system.

Connection of the smoke aspiration system:

- ◆ Connect the pipe between the smoke aspiration system and the Purging unit.
- ◆ If you have temporarily, for the time of commissioning, connected a 5.6kOhm resistor – instead of the smoke aspiration system – to the fault input of the Purging unit, remove the resistor and properly connect the smoke aspiration system.
- ◆ Commission the smoke aspiration system according to the information provided by its manufacturer.

Parameterisation:

- ◆ On the Purging unit, set the time, the device number – if applicable – as well as the Purging program.
- ◆ Does the „status LED“ of the Purging unit illuminate green?

Carrying out the Purging process:

- ◆ Turn on the compressed-air supply to the Purging unit **slowly**, so that the pressure can build up slowly.
- ◆ Simulate a fault of the smoke aspiration system (the „status LED“ of the Purging unit is blinking yellow).
- ◆ Check whether the Purging process is carried out properly (the switching of the valve as well as the flow of the compressed air are clearly audible – the „status LED“ of the Purging unit alternately illuminates red and green as long as the solenoid valve is activated).
- ◆ Check whether the fault that still exists is transmitted to the fire detection control panel and is correctly indicated there after the Purging process has been carried out (one minute after completion of the Purging process, the „status LED“ of the Purging unit will change from blinking yellow to illuminated yellow and the fault will be transmitted to the fire detection control panel).
- ◆ Terminate the fault condition of the smoke aspiration system.
- ◆ After that, is the fault automatically reset again on the fire detection control panel?



Only after checking whether the fault has been transmitted will it be ensured that the indication of the fault of the smoke aspiration system has been properly carried out right up to the fire detection control panel.



According to most of the European installation regulations as well as the relevant European Standards EN 54, all lines for the indication and transmission of the faults must be monitored and a wire breakage as well as a fault of the devices must be indicated.

A failure of the supply voltage of the Purging unit will also activate the fault output of the Purging unit, and therefore it will be indicated on the fire detection control panel as fault.

Showing the user what to do:

- ◆ Inform the user about possible limitations and dangers of the operation of the Purging unit and train the user in the proper handling as well as the correct use and operation of the unit.

10 Inspection

Only flawless high-quality parts are used for the production of the Automatic Purging Units Series F-BO-AFE70-2. Nevertheless, all used parts are subject to natural aging and wear. For reasons of safety it is therefore recommended that the Automatic Purging Units Series F-BO-AFE70-2 should be replaced with new units after 10 years of operation.

Under normal environmental conditions, a visual inspection and a functional check of the Automatic Purging Unit Series F-BO-AFE70-2 should be carried out once a year. On this occasion, the correct operation of the electronics as well as of the mechanics must be checked.

For this purpose it is not necessary to disassemble the Automatic Purging Units Series F-BO-AFE70-2, removing the cover after loosening the two screws is sufficient.

In the course of the visual inspection, all components that are accessible after removing the cover have to be examined for damage and aging.

Check whether all screws have been securely tightened and, if necessary, tighten them.

The proper functioning of the electronics, including the transmission of faults to the fire detection control panel is to be checked by simulating the operating conditions on the evaluation unit of the smoke aspiration system or on the terminals of the F-BO-AFE70-2.

To check the proper mechanical functioning, an acoustic check together with the check of the measured air flow values on the smoke aspiration system are enough:

- ◆ When the Purging process is started, a shock which can be felt with the hand and which is clearly audible without any aid must be perceptible. This indicates that the piston has opened completely, the air flow to the smoke aspiration system has been interrupted and the compressed air is being introduced into the pipe network. The piston is in the Purging position. In this state, the measured air flow value on the smoke aspiration system must clearly change into the fault range.
- ◆ After completion of the Purging process, a soft shock must be audible. This indicates that the piston is pushed back completely, up to the aluminium cover of the housing. The piston is in the idle position again. Whether the piston has been pushed back properly can also be observed with the air flow measurement of the smoke aspiration system; the measured value must return to the value before the start of the Purging process.



Since the second shock is relatively soft, a suitable sound bridge can be used between the aluminium housing and the ear, in order to improve the sound transmission.

If you are not sure that the piston can freely move between idle position – Purging position – idle position, the Automatic Purging Unit F-BO-AFE70-2 must be replaced.



The Automatic Purging Units Series F-BO-AFE70-2 are high-precision devices that are assembled and function-tested with special equipment and know-how. Disassembly and reassembly without this equipment or without appropriate know-how can lead to malfunctions which can result in risk of injuring persons and in damage to property, and therefore has to be refrained from.

11 Specifications



The specifications that are stated in the sections that follow are – with the exception of the values that are given as maximum or minimum values – typical values which are subject to manufacturing tolerances.

Housing	
Installation	wall installation, surface type
Material	sheet steel, powder coated (cover) sheet steel, galvanised (bottom plate) aluminium, anodized (valve block)
Colour	graphite black, RAL 9011 (cover)
Protection class	IP10B (condition on delivery) IP20D (expertly installed)
Dimensions W × H × D (excl. push-in fittings)	204 × 68 × 160 (mm)
Dimensions W × H × D (incl. push-in fittings)	204 × approx. 201 × 160 (mm)
Weight F-BO-AFE70-2-1	approx. 3.2kg
Weight F-BO-AFE70-2-2	approx. 3.2kg
Ambient temperature	+5°C to +50°C
Relative humidity	max. 95% at 40°C, (no condensation)
Accuracy of the timer	±11 minutes per year
Supply voltage	
Normal operation	21.6 ... 30.0VDC
Solenoid valve continuously energised	21.6 ... 26.4VDC
Current consumption at 24V	
F-BO-AFE70-2-1	8mA (normal condition, solenoid valve de-energised) 450mA (solenoid valve energised)
F-BO-AFE70-2-2	8mA (normal condition, solenoid valve de-energised) 300mA (solenoid valve energised)
Minimum output current of the power unit	1.5A
Connection type	pluggable screw terminals, 2-pin
Wire gauge	max. 2.5mm ² (single-wire)
Fault input (terminals 3, 4)	
Minimum activation time	1 sec.
Line resistance	max. 50Ω per core
End-of-line resistor	REOL AFE 5.6kΩ
Short circuit interruption	< 200Ω > 7.5kΩ
Input 'Manual activation' (terminals 11, 12)	
Minimum activation time	125ms
Line resistance	max. 50Ω per core
Output 'Slave activation' (terminals 5, 6)	
Contact type	semiconductor switch, normally open contact, potential-free
Switching power	max. 30V (internal protective resistor 6.8kΩ)
Fault output (terminals 7, 8)	
Contact type	semiconductor switch, normally closed contact, potential-free
Switching power	max. 30V/ max. 120mA
Compressed air characteristics F-BO-AFE70-2-1 (ANR means: at 0.1MPa (1bar), 20°C, 65% relative humidity)	
Compressed-air connection	G1/4" female thread with straight push-in fitting screwed on for hose with outer diameter of 10mm

Overpressure permissible at the input	0.00 ... 1.00MPa (0.0 ... 10.0bar)
Recommended overpressure at the input	0.20 ... 1.00MPa (2.0 ... 10.0bar)
Flow rate solenoid valve	0.4MPa: typ. 600 l/min (ANR) 0.6MPa: typ. 800 l/min (ANR) 0.8MPa: typ. 1,100 l/min (ANR) 1.0MPa: typ. 1,400 l/min (ANR)
Compressed air characteristics F-BO-AFE70-2-2 (ANR means: at 0.1MPa (1bar), 20°C, 65% relative humidity)	
Compressed-air connection	G3/8" female thread with 90-degree push-in fitting screwed on for hose with outer diameter of 10mm
Overpressure permissible at the input	0.02 ... 0.70MPa (0.2 ... 7.0bar)
Recommended overpressure at the input	0.20 ... 0.70MPa (2.0 ... 7.0bar)
Flow rate solenoid valve	0.2MPa: typ. 1,300 l/min (ANR) 0.4MPa: typ. 2,300 l/min (ANR) 0.6MPa: typ. 3,200 l/min (ANR) 0.7MPa: typ. 3,700 l/min (ANR)

12 Set parameters

System: _____

	SW1	Purging program
	0	<i>Setting the time – manual activation not possible</i>
<input type="checkbox"/>	1	Once a day at 10:00 and in case of a fault, always with long Purging process
<input type="checkbox"/>	2	Twice a day at 09:00 and 14:00 and in case of a fault, always with long Purging process
<input type="checkbox"/>	3	Three times a day at 06:00, 12:00 and 18:00 and in case of a fault, always with long Purging process
<input type="checkbox"/>	4	Four times a day at 5:00, 10:00, 15:00 and 20:00 and in case of a fault, always with long Purging process
<input type="checkbox"/>	5	Six times a day at 4:00, 8:00, 12:00, 16:00, 20:00 and 00:00 and in case of a fault, always with long Purging process
<input type="checkbox"/>	6	Long Purging process in the event of a fault of the evaluation unit of the smoke aspiration system. This program is also to be used if the Purging processes are only started by a push-button, or if the Purging unit operates as „slave“.
<input type="checkbox"/>	7	Once a day at 10:00 and in case of a fault, always with short Purging process
<input type="checkbox"/>	8	Twice a day at 09:00 and 14:00 and in case of a fault, always with short Purging process
<input type="checkbox"/>	9	Three times a day at 06:00, 12:00 and 18:00 and in case of a fault, always with short Purging process
<input type="checkbox"/>	A	Four times a day at 5:00, 10:00, 15:00 and 20:00 and in case of a fault, always with short Purging process
<input type="checkbox"/>	B	Six times a day at 4:00, 8:00, 12:00, 16:00, 20:00 and 00:00 and in case of a fault, always with short Purging process
<input type="checkbox"/>	C	Short Purging process in the event of a fault of the evaluation unit of the smoke aspiration system
	D	<i>No Purging program; a fault will be transmitted without delay, manual activation is not possible</i>
	E	<i>No Purging program; a fault will be transmitted without delay, manual activation is not possible</i>
	F	<i>Setting the device number</i> Device number: _____ – manual activation not possible

Table 9: *Set parameters of the Automatic Purging Units Series F-BO-AFE70-2
 Switch position of the rotary switch „Purging program“ SW1 as well as device number*